



पंडित दीनदयाल उपाध्याय शेखावाटी विश्वविद्यालय, सीकर (राज)

वेबसाइट www.shekhawati.ac.in ई-मेल: reg.shekhawati@gmail.com

क्रमांक: 26274

दिनांक: 24/10/2024

ई-निविदा संख्या 14/2024-25

**Tender of Furnishing/Interior Works for New Guest
House Building/Student Union Office Building/Dispensary
Building/Canteen Building and University Campus Entrances at
Pandit Deendayal Upadhyaya Shekhawati University, Sikar (Raj.)**

Mode of Bid Submission	On Line (E-Tender)
Procuring Entity	Registrar Pandit Deendayal Upadhyaya Shekhawati University, Sikar 332024
Estimated Cost of Tender	3,25,00,000/-
Tender Opening Date	24.10.2024
Last date & Time of On-line submission of Technical Bid	12.11.2024
Last date & time of submission of DD of EMD processing fee & Tender fee in office	12.11.2024 till 05.00 PM
Last date & time of submission of Product Samples	12.11.2024 till 05.00 PM
Date & time of opening of On-Line Technical Bid	13.11.2024 at 03.00 PM

- Cost of E-Tender Document and fee in favour of Registrar, Pandit Deendayal Upadhyaya Shekhawati University, Sikar Rs. 3000/-
- EMD Bid security for the tender cost @ 2% i.e. Rs. 6,50,000/-
- E-Tender processing fee in favour of MD, RISL, Jaipur Rs. 2000/-

Registrar

Pandit Deendayal Upadhyaya
Shekhawati University, Sikar

Name & Signature of Bidder with Seal



पंडित दीनदयाल उपाध्याय शेखावाटी विश्वविद्यालय, सीकर (राज)

वेबसाईट: www.shekhauni.ac.पद ई-मेल: reg.shekhauni@gmail.com

ई-निविदा संख्या 14/2024-25 (तकनीकी बिड़)

1. बोलीदाता/संवेदक का नाम, डाक का पता व टेलीफोन/मोबाईल नम्बर
.....
2. किसको सम्बोधित किया-कुलसचिव, पंडित दीनदयाल उपाध्याय शेखावाटी विश्वविद्यालय, सीकर।
3. सन्दर्भ : आपकी ई-निविदा सूचना क्रमांक 14/2024-25 दिनांक 24.10.2024
4. हम कुलसचिव, पंडित दीनदयाल उपाध्याय शेखावाटी विश्वविद्यालय, सीकर द्वारा जारी की गई निविदा सूचना दिनांक 24.10.2024 में वर्णित सभी शर्तों से तथा संलग्न शीट में दी गई उक्त ई-निविदा सूचना की अतिरिक्त शर्तों से बाध्य होना स्वीकार करते हैं। इनके सभी पृष्ठों पर उनमें उल्लेखित शर्तों को हमारे द्वारा स्वीकार किए जाने के प्रमाण में हम ने हस्ताक्षर कर दिये हैं।
5. ब्लैकलिस्ट नहीं होने का शपथ-पत्र (100 रुपये के नॉनजुडिशियल स्टाम्प पर)
6. बैंकड्राफ्ट/बैंकर्स चेक संख्यादिनांक.....
.....(जारी कर्ता बैंक का नाम) रुपये 6,50,000/- के लिए अमानत राशि के पेटे संलग्न है। जो कुलसचिव, पंडित दीनदयाल उपाध्याय शेखावाटी विश्वविद्यालय, सीकर को देय हो।
7. बैंकड्राफ्ट सं०दिनांकराशि 3000/-
.....(जारीकर्ता बैंक का नाम) जो कुलसचिव, पंडित दीनदयाल उपाध्याय शेखावाटी विश्वविद्यालय, सीकर को देय हो (निविदा शुल्क के पेटे संलग्न)
8. बैंकड्राफ्ट सं०दिनांकराशि 2000/-.....
... (जारीकर्ता बैंक का नाम) जो MD RISEL, Jaipur को देय हो वास्ते (प्रोसेसिंग फीस के पेटे संलग्न)

निविदादाता के हस्ताक्षर

GENERAL INSTRUCTIONS TO BIDDERS

1. Eligibility Criteria: The present tender is being invited for Furnishing/Interior Works for New Guest House Building/Student Union Office Building/Dispensary Building/Canteen Building and University Campus Entrance gates :-

1. The Bidder should be an OEM and should sufficiently be equipped and experienced to manufacture and supply of custom made furniture. The bidder should furnish Factory License/ Proof of OEM.
2. The Bidder should have successfully executed orders of manufacturing and supply of furniture to the Central Government / State Government / Public Sector Organizations / Undertakings / Central or State Government Universities / State level Board. The Bidder has to furnish a copy of one similar work order having value of more than 160 lakhs or furnish copy of two similar work orders having value of more than 100 lakhs each or furnish copy of three similar work orders having value of more than 75 lakhs completed in the past five years.
3. Bidder should have annual turnover of more than Rs. 2.00 Crore in any one of the last three financial years (2020-2021 / 2021-2022 / 2022-2023). Bidder to furnish CA certified annual turnover certificate.
4. Bidder to furnish Pan card, GST certificate, Partnership Deed and MSME certificate.
5. ESIC/PF document of the bidder to be furnished.
6. The bidder should have ISO, BIFMA, GREEN GUARD compliance. Certificates to be furnished.
7. Bidders to submit samples of each items as per Annexure-A before the last date of bid submission. Technical bids shall be rejected of all bidders who fail to submit all the samples (as per annex A) before the last date of bid submission. Only the bidders whose samples meet all specifications/quality/technical parameters shall qualify for technical bid evaluation.
8. The bidder should furnish details of contact person, address of factory, bank details etc. on their letter head.
9. Bidder to ascertain site conditions as per scope of work.
10. Prices quoted by the bidder shall be inclusive of all labour, material, installation, transportation, taxes etc. with 1 year on-site warranty, complete in all respect.

General Specifications and Approved Make

- 1) Wood: Superior quality kiln dried first class teak wood / sheesham wood to be used having moisture content not more than 12%. Tenon and mortise joinery to be used in wood joints. The wood used shall not have sap wood content of more than 10%.
- 2) Plywood: Approved make Greenply, Century Ply, Duro or similar.
- 3) Veneer: Approved make Greenply, Century Ply, Duro or similar (Natural wood veneer).
- 4) Laminate: Approved make Greenlam, Century Ply or similar.
- 5) Fabric: Good quality fabric/leatherette (estimated cost Rs. 800/- per meter). Approved brand D'décor, Sarom, Decomax or similar.
- 6) Mattress / Foam: Approved brand Sleep well, Feather Foam, Kurlon or similar.
- 7) Hardware: Good quality hardware from reputed brands such as Hettich, Hafele and Eboas per approved designs.
- 8) Wood Polish: All wood and veneer surface to be sanded smooth and surface to be prepared with fillers and sealers. 03 coats of premium of polyurethane lacquer in satin finish to be applied for a smooth and protective finish.
- 9) Metal Coating: All metal surfaces shall be powder coated.
- 10) Testing / Certificates: Random samples of wood shall be taken by the client from the production/finished product and shall be sent for testing. Cost incurred towards testing shall be borne by the successful bidder.

2. ONE BID PER BIDDER:-

Each bidder shall submit only one tender either by himself or as a partner in joint venture or as a member of consortium. If a bidder or if any of the partners in a joint venture or any one of the members of the consortium participate in more than one bid, the bids are liable to be rejected.

Joint Venture/Consortium is not allowed for this bid.

3. BID PRICES:-

Bidder shall quote separately the Item wise rates in Indian Rupees. The tendered rates include all the liabilities of the contractor such as statutory liabilities like Minimum Wages, ESI, PF contributions, service charges, except Goods and Service Tax (GST), cost of uniform and identity cards of personnel deployed by the firm/contractor and all consumables, tools & plants, machines, vehicles etc. required for the smooth and satisfactory execution of the work which should be clearly stated by the contractor. The statutory deductions like income tax, work contract tax etc. (wherever applicable) shall be made from the bills of the firm/contractor. Bidder shall quote his rates with GST in financial bid.

Conditional bids/offers will be summarily rejected.

4. FORM OF BID:-

The Form of Bid shall be completed in all respects and duly signed and stamped by an authorized and empowered representatives of the Bidder. If the Bidder comprises a partnership firm, consortium or a jointventure, the Form of Bid shall be signed by a duly authorized representative of each member of participant thereof.

5. Work Completion Period:-

The time allowed for completion of work shall be sixty days from the date of award of the work.

6. Right to accept any Bid and to reject any or all Bids:-

University is not bound to accept the lowest or any other bid and may reject any or all the bids without assigning any reason.

University may terminate the contract if it is found that the agency is black listed on previous occasions by any of the Govt. Deptt./Institutions/Local Bodies/Municipalities/Public Sector Undertakings, etc.

University may reject the Bid in the event that the Bid is accepted but the successful bidder fails to furnish the Performance Security or fails to execute the contract agreement.

7. Award of Contract:-

University will award the contract to the successful evaluated bidder whose bid has been found to be responsive and who is eligible and qualified to perform the contract satisfactorily as per the terms and conditions incorporated in the bidding document.

University will communicate the successful bidder that his bid has been accepted. This letter (hereinafter and in the condition of contract called the "Letter of Offer") shall prescribe the amount which University will pay to the contractor in consideration of the execution of work/services by the contract or as prescribed in the contract. The successful bidder will be required to execute a contract agreement within a period of 15 days from the date of issue of Letter of Offer.

The successful bidder shall be required to furnish a performance Security within 10 days of receipt of 'Letter of Offer' for an amount of 5% of total value of the contract (2% EMD will be adjusted) in the shape of Bank Guarantee/ Demand Draft/ Fixed Deposit issued from a scheduled bank in favour of Registrar, PANDIT DEENDAYAL UPADHYAYA SHEKHAWATI UNIVERSITY, SIKAR. In case the contract period is extended further, the validity of Performance Security shall also be extended by the contractor accordingly.

Signature of Bidder with Seal

8. General Terms & Conditions:

1. In case any public complaint is received attributable to misconduct/ misbehaviour of firm/contractor's personnel, a penalty of Rs. 2000/- for each such incident shall be levied and the same shall be deducted from contractor's bill. Further the concerned contractor's personnel shall be removed from the system immediately.
2. *In case the contractor fails to commence/execute the work as stipulated in the agreement or unsatisfactory performance or does not meet the statutory requirements of the contract, the Vice-Chancellor reserves the right to forfeit the EMD and performance security and the firm will be blacklisted for a period of four years from participating in such type of tender.*
3. University reserves the right to cancel or reject all or any of the tender without assigning any reason.
4. Any act on the part of the tenderer to influence any body in the University is liable to rejection of his tender.
5. *Every employee so engaged by the contractor shall wear uniform and a badge wearing his/her name, while on duty. The said uniform and badge shall be provided by the contractor at his own cost.*
6. The firm/contractor shall engage the men/women whose age shall be between 21-63 years duly trained for the job.
7. The contractor shall abide by and comply with all the relevant laws and statutory requirements covered under Labour Act, Minimum Wages and Contract Labour (Regulation & Abolition Act 1970), EPF, ESI, Bonus, Gratuity, Leave etc. with regard to the personnel engaged by him.
8. The contractor shall not engage any sub-contractor or transfer the contract to any other person in any manner.
9. All liabilities arising out of accident or death while on duty shall be borne by the contractor.
10. The contractor and its staff shall take proper and reasonable precautions to preserve from loss, destruction, waste or misuse the areas of responsibility given to them by the University and shall not knowingly lend to any person or company any of the effects of the University under its control.
11. The contractor shall be responsible to maintain all property and equipment of the University entrusted to it. Any damage or loss caused by contractor's persons to the University in whatever shape would be recovered from the contractor.
12. That in the event of any loss occasioned to the University as a result of any lapse on the part of the contractor which will be established after an enquiry conducted by the University the said loss shall be claimed from the contractor up to the value of the loss. The decision of the Head of the University will be final and binding on the contractor.
13. Any liability arising out of any litigation (including those in consumer courts) due to any act of contractor/firm and its personnels shall be directly borne by the contractor including all expenses/fines. The concerned contractor's personnel shall attend the court as and when required.
14. If any money shall, as the result of any instructions from the Labour authorities or claim or application made under any of the Labour laws or Regulations, be directed to be paid by the University, such money shall be deemed to be payable by the contractor to the University within seven days. The University shall be entitled to recover this amount

- from the contractor by deduction from money due to contractor.
15. The contractor shall indemnify and hold the University harmless from and against all claims, damages, losses and expenses arising out of, or resulting from the works/services under the contract provided by the contractor.
 16. The University shall not be responsible for providing residential accommodation to any of the personnel of the contractor.
 17. The contractor shall provide the copies of relevant records during the period of contract or otherwise even after the contract is over whenever required by the University.

9. Dispute Resolution:-

Any dispute and or difference arising out of or relating to this contract will be resolved through joint discussion of the authorities' representatives of the concerned parties. However, if the disputes are not resolved by joint discussions, then the matter will be referred for adjudication to a sole Arbitrator appointed by the Vice Chancellor, PANDIT DEENDAYAL UPADHYAYA SHEKHAWATI UNIVERSITY, SIKAR.

The award of the sole Arbitrator shall be final and binding on all the parties. The arbitration proceeding's shall be governed by Indian Arbitration and Conciliation Act 1996 as amended from time to time.

The cost of Arbitration shall be borne by the respective parties in equal proportions. During the pendency of the arbitration proceeding and currency of contract, neither party shall be entitled to suspend the work/service to which the dispute relates on account of the arbitration and payment to the contractor shall continue to be made in terms of the contract.

Jurisdiction of court:-

The Sikar courts shall have the exclusive jurisdiction to try all disputes, if any, arising out of this agreement between the parties.

10. Payment to the contractor:

The work has been satisfactorily executed, as per the Terms & Conditions of the contract, for which the contractor has raised the bill.

Signature of Bidder with Seal

Item Specifications / Schedule of Quantity

S.No.	Item / Specifications	Unit	Qty	Reference Drawing Number / Reference Image
1.	<p>Main Entrance Gates : Providing and Fixing Double Leaf Entrance Gates of approx. size 19.5 ft. (w) x 25 ft. (h) at main entrance of the university campus. The provided overall dimensions of the gate are approximate, exact dimensions & curvature to be obtained from the site. The entrance gates shall be made with first class teak wood cladding on both front & back side with M.S. support inner-structure. The M.S. support structure shall be made with 100x50mmx3mm thick m.s. tube on the outer periphery welded together with 50x25mmx2mm m.s. tubes for internal supports vertical & horizontal. Wooden cladding on both sides (front & back) of the gates shall be done using first class teak wood. Wooden frame at the outer periphery shall be made using 150x18mm section teak wood & inner wooden grid shall be made using 58x18mm teak wood battens fixed over 18mm thick teak wood base panel. The gates shall be fixed on the wall using heavy duty M.S. bush hinges of size 50x220mm, the distance between each hinge shall not be more than 1000mm. Additionally gate shall also have male female hinges fixed at the bottom. All hinges shall be welded to the gate M.S. support inner-structure and grouted into the wall. The M.S. support inner-structure and hinges shall be black powder coated 40-50 microns thick. Superior quality kiln dried first class teak wood having moisture content not more than 12% and processed with anti-termite treatment in a pressurized chamber to be used. All teak wood surface shall be sanded smooth and sealed with epoxy coating for enhanced moisture/weather resistance. 03 coats of exterior grade polyurethane lacquer shall be applied as top coat along with 02 coats of polyurethane sealer as base coat. 50mm dia decorative brass flowers fixed with brass nails shall be provided at each intersection of teak wood grid. Good quality water resistant wood adhesive along with nails & S.S. screws to be used for wood joinery. All complete including M.S. fabrication work, wood work, polishing work, civil /masonry work, scaffolding, crane lifting etc. as per detailed drawing and directions of officer in-charge.</p>	pcs.	2	REFER DRAWING NO. 1
2.	<p>Main Entrance Gates : Providing and Fixing Double Leaf Entrance Gates of approx. size 12 ft. (w) x 17 ft. (h) at main entrance of the university campus. The provided overall dimensions of the gate are approximate, exact dimensions & curvature to be obtained from the site. The entrance gates shall be made with first class teak wood cladding on both front & back side with M.S. support inner-structure. The M.S. support structure shall be made with 100x50mmx3mm thick m.s. tube on the outer periphery welded together with 50x25mmx2mm m.s. tubes for internal supports vertical & horizontal. Wooden cladding on both sides (front & back) of the gates shall be done using first class teak wood. Wooden frame at the outer periphery shall be made using 150x18mm section teak wood & inner wooden grid shall be made using 58x18mm teak wood battens fixed over 18mm thick teak wood base panel. The gates shall be fixed on the wall using heavy duty M.S. bush hinges of size 50x220mm, the distance between each hinge shall not be more than 1000mm. Additionally gate shall also have male female hinges fixed at the bottom. All hinges shall be welded to the gate M.S. support inner-structure and grouted into the wall. The M.S. support inner-structure and hinges shall be black powder coated 40-50 microns thick. Superior quality kiln dried first class teak wood having moisture content not more than 12% and processed with anti-termite treatment in a pressurized chamber to be used. All teak wood surface shall</p>	pcs.	2	REFER DRAWING NO. 2



	be sanded smooth and sealed with epoxy coating for enhanced moisture/weather resistance. 03 coats of exterior grade polyurethane lacquer shall be applied as top coat along with 02 coats of polyurethane sealer as base coat. 50mm dia decorative brass flowers fixed with brass nails shall be provided at each intersection of teak wood batten grid. Good quality water resistant wood adhesive along with nails & S.S. screws to be used for wood joinery. All complete including M.S. fabrication work, wood work, polishing work, civil /masonry work, scaffolding, crane lifting etc. as per detailed drawing and directions of officer in-charge.			
3.	Bed : Supply and installation of Bed size 1940x2180x1550mm made of solid sheesham wood to accommodate mattress size 72"x78". Bed headboard size 1940x38x1550mm made of sheesham wood having legs /frame section 60x38mm, bottom horizontal frames section 210x25mm. Bed headboard shall be upholstered in tufted design using 70mm thick PU foam of 40 density pasted over 18mm thick BWP plywood and covered with good quality fabric of approved brand costing approx. 800 per meter. Bed footboard size 1940x85x450mm made of solid sheesham wood having legs section 60x60mm, 2 nos. horizontal frames section 30x25mm & 60x25, 01 nos. horizontal raised panel section 205x25mm, 01 nos. top horizontal panel 85x35mm. Bed side rails made of solid sheesham wood section 210x28mm. The bed shall have 18mm thick BWP plywood top to place the mattress which is supported with 01 no. of sheesham wood panel of section 130x28mm & 04 nos. sheesham wood panel of section 80x30mm and 20x18mm battens to place the plywood. A slot of 72"x78" to be provided for the mattress. Wood carving on headboard & footboard and other details to be followed as per reference detailed drawing. Superior quality kiln dried sheesham wood having moisture content not more than 12% and processed with anti-termite treatment in a pressurized chamber to be used. All wood frames/legs/panels shall be joined together using precise mortise & tenon joinery with high quality D3 grade wood glue. All wood surface shall be finished in approved shade of polish with 03 coats of polyurethane lacquer in satin finish with prior sanding, sealing with fillers and polyurethane sealer. All complete as per detailed drawing and directions of officer in-charge.	pcs.	2	REFER DRAWING NO. 3
4.	Bedside Cabinet : Supply and installation of Bedside Cabinet size 600x400x650mm made of solid sheesham wood / sheesham veneer/ plywood /stone top. Cabinet top shall have 18mm thick Italian marble with high quality polyester coating and edge moulding, the Italian marble shall be pasted on 18mm thick BWP plywood and covered with sheesham wood molding on all edges. Legs section 38x38mm, horizontal frames at front/side/back section 40x25mm/30x25/20x25 made of solid sheesham wood. Cabinet side panels shall be made from sheesham veneer pasted on 12mm thick BWP plywood. The cabinet shall have 03 nos. of drawer for storage having front raised panel design. Drawer front panel made of sheesham wood section 140x25mm, drawer side/back panels made of 18mm thick BWP plywood with sheesham pasting and edges covered with 8mm thick sheesham wood lipping & drawer base in 9mm thick BWP plywood with sheesham veneer pasting. Good quality telescopic channel & handle in antique finish of approved design & brand to be provided for drawer. Wood carving and other details to be followed as per reference detailed drawing. Superior quality kiln dried sheesham wood having moisture content not more than 12% and processed with anti-termite treatment in a pressurized chamber to be used. All wood frames/legs/panels shall be joined together using precise mortise & tenon joinery with high quality D3 grade wood glue. All wood surface shall be finished in approved shade of polish with 03 coats of polyurethane lacquer in satin finish with prior sanding, sealing with fillers	pcs.	4	REFER DRAWING NO. 4

M

	and polyurethane sealer. All complete as per detailed drawing and directions of officer in-charge.			
5.	Desk with Fridge Cabinet : Supply and installation of Desk with Fridge Cabinet size 2600x550x750mm made of solid sheesham wood / sheesham veneer/ plywood /stone top. Top shall have 18mm thick Italian marble with high quality polyester coating and edge moulding, the Italian marble shall be pasted on 18mm thick BWP plywood and covered with sheesham wood molding on all edges. Legs section 50x50mm, horizontal frames at front/back section 60x25mm made of solid sheesham wood. Side panels shall be made from white sheesham veneer pasted on 18mm thick BWP plywood. The cabinet shall have 01 nos. of storage compartment (for mini fridge) made of sheesham veneer pasted on 18mm thick BWP plywood 01 nos. shutter made of 40x25mm section sheesham wood battens. Handle in antique finish of approved design & brand to be provided. Wood carving and other details to be followed as per reference detailed drawing. Superior quality kiln dried sheesham wood having moisture content not more than 12% and processed with anti-termite treatment in a pressurized chamber to be used. All wood frames/legs/panels shall be joined together using precise mortise & tenon joinery with high quality D3 grade wood glue. All wood surface shall be finished in approved shade of polish with 03 coats of polyurethane lacquer in satin finish with prior sanding, sealing with fillers and polyurethane sealer. All complete as per detailed drawing and directions of officer in-charge.	pcs.	2	REFER DRAWING NO. 5
6.	Chair with Armrest : Supply and installation of Chair with Armrest size 600x580x1030 mm made of solid sheesham wood / upholstery work. sheesham wood front legs section 50x50 mm tapered to 30x30 mm at the bottom, curved back legs section 35x35mm at the center gradually tapering down to 30x30mm at the top & bottom, chair seat apron section 60x25mm (front/back/side), armrest wood section 40x35mm, chair back horizontal panels wood section 35x30mm made of sheesham wood. Chair seat & back to have 12mm thick BWP plywood base upholstered using 50mm thick 40 density PU foam covered with good quality fabric of approved brand costing approx. 800 per meter. Wood carving and other details to be followed as per reference detailed drawing. Superior quality kiln dried sheesham wood having moisture content not more than 12% and processed with anti-termite treatment in a pressurized chamber to be used. All wood frames/legs/panels shall be joined together using precise mortise & tenon joinery with high quality D3 grade wood glue. All wood surface shall be finished in approved shade of polish with 03 coats of polyurethane lacquer in satin finish with prior sanding, sealing with fillers and polyurethane sealer. All complete as per detailed drawing and directions of officer in-charge.	pcs.	6	REFER DRAWING NO. 6
7.	Luggage Table : Supply and installation of Luggage Table size 900x600x650mm made of solid sheesham wood / sheesham veneer/ plywood /stone top. Top shall have 18mm thick Italian marble with high quality polyester coating and edge moulding, the Italian marble shall be pasted on 18mm thick BWP plywood and covered with 53x18mm sheesham wood molding on all edges. Legs section 38x38mm, horizontal frames at front/side/back section 30x25mm & 40x25mm made of solid sheesham wood. Side panels shall be made from sheesham veneer pasted on 18mm thick BWP plywood. The table shall have 01 nos. of storage shelf made of sheesham veneer pasted on 18mm thick BWP plywood, the base of table shall be made from sheesham veneer pasted on 18mm thick BWP plywood. Wood carving and other details to be followed as per reference detailed drawing. Superior quality kiln dried sheesham wood having moisture content not more than 12% and processed with anti-termite treatment in a pressurized chamber to be used. All wood frames/legs/panels shall be joined together using precise	pcs.	2	REFER DRAWING NO. 7

	mortise & tenon joinery with high quality D3 grade wood glue. All wood surface shall be finished in approved shade of polish with 03 coats of polyurethane lacquer in satin finish with prior sanding, sealing with fillers and polyurethane sealer. All complete as per detailed drawing and directions of officer in-charge.			
8.	Wardrobe : Supply and installation of Wardrobe size 1050x600x2100mm made of solid sheesham wood / sheesham veneer/ plywood. Top made of sheesham veneer pasted on 18mm thick BWP plywood and covered with 60x18mm sheesham wood molding on all edges. Legs section 60x60mm, horizontal frames at front/side/back section 40x25mm & 60x25mm made of solid sheesham wood. Side panels shall be made from sheesham veneer pasted on 18mm thick BWP plywood. Wardrobe shutter frames made of 60x28mm section sheesham wood along with natural rattan cane mesh panels. The wardrobe shall have two shelves for storage made of sheesham veneer pasted on 18mm thick BWP plywood. Wardrobe back shall have veneer pasted on 9mm thick BWP plywood. Handle in antique finish, hanger rod, hinges of approved design & brand to be provided. Wood carving and other details to be followed as per reference detailed drawing. Superior quality kiln dried sheesham wood having moisture content not more than 12% and processed with anti-termite treatment in a pressurized chamber to be used. All wood frames/legs/panels shall be joined together using precise mortise & tenon joinery with high quality D3 grade wood glue. All wood surface shall be finished in approved shade of polish with 03 coats of polyurethane lacquer in satin finish with prior sanding, sealing with fillers and polyurethane sealer. All complete as per detailed drawing and directions of officer in-charge.	pcs.	2	REFER DRAWING NO. 8
9.	Sofa Chair : Supply and installation of Sofa Chair size 700x700x980mm made of solid sheesham wood and upholstery work. Seat inner frame and structure made of 70x28mm section hardwood having s-springs & elastic bands and upholstered using PU foam and good quality fabric of approved shade and texture costing approx. Rs. 800 per mtr. Seat foam 120mm thick of density 40kg/m ³ and back foam 75mm thick of density 40kg/m ³ . Chair seat apron section 50x25mm, front legs wood section 60x60mm, curved back legs wood section 60x60mm, armrest wood section 50x48mm, back horizontal section 50x30mm made of sheesham wood. Wood carving and other details to be followed as per reference detailed drawing. Superior quality kiln dried sheesham wood having moisture content not more than 12% and processed with anti-termite treatment in a pressurized chamber to be used. All wood frames/legs/panels shall be joined together using precise mortise & tenon joinery with high quality D3 grade wood glue. All wood surface shall be finished in approved shade of polish with 03 coats of polyurethane lacquer in satin finish with prior sanding, sealing with fillers and polyurethane sealer. All complete as per detailed drawing and directions of officer in-charge.	pcs.	8	REFER DRAWING NO. 9
10.	Sofa 03 Seater : Supply and installation of Sofa 03 seater size 2496x920x850mm made of solid sheesham wood and tufted upholstery work. Seat inner frame and structure made of 70x30mm section hardwood having s-springs & elastic bands and upholstered using PU foam and good quality fabric of approved shade and texture costing approx. Rs. 800 per mtr. Seat foam 150mm thick of density 40kg/m ³ and back/armrest foam 75mm thick of density 40kg/m ³ . Sofa seat apron section 60x28mm, legs wood section 110x110mm made of sheesham wood. Sofa back and armrest shall have tufted design upholstery work along with antique finish decorative tack nails work. Wood carving and other details to be followed as per reference detailed drawing. Superior quality kiln dried sheesham wood having moisture content not more than 12% and processed with	pcs.	2	REFER DRAWING NO. 10

M

	anti-termite treatment in a pressurized chamber to be used. All wood frames/legs/panels shall be joined together using precise mortise & tenon joinery with high quality D3 grade wood glue. All wood surface shall be finished in approved shade of polish with 03 coats of polyurethane lacquer in satin finish with prior sanding, sealing with fillers and polyurethane sealer. All complete as per detailed drawing and directions of officer in-charge.			
11.	Sofa 02 Seater : Supply and installation of Sofa 02 seater size 1895x920x850mm made of solid sheesham wood and tufted upholstery work. Seat inner frame and structure made of 70x28mm section hardwood having s-springs & elastic bands and upholstered using PU foam and good quality fabric of approved shade and texture costing approx. Rs. 800 per mtr. Seat foam 150mm thick of density 40kg/m3 and back/armrest foam 75mm thick of density 40kg/m3. Sofa seat apron section 60x28mm, legs wood section 110x110mm made of sheesham wood. Sofa back and armrest shall have tufted design upholstery work along with antique finish decorative tack nails work. Wood carving and other details to be followed as per reference detailed drawing. Superior quality kiln dried sheesham wood having moisture content not more than 12% and processed with anti-termite treatment in a pressurized chamber to be used. All wood frames/legs/panels shall be joined together using precise mortise & tenon joinery with high quality D3 grade wood glue. All wood surface shall be finished in approved shade of polish with 03 coats of polyurethane lacquer in satin finish with prior sanding, sealing with fillers and polyurethane sealer. All complete as per detailed drawing and directions of officer in-charge.	pcs.	4	REFER DRAWING NO. 11
12.	Centre Table : Supply and installation of Centre Table size 750Dia x 450mm made of solid sheesham wood / plywood /stone top. Top shall have 18mm thick Italian marble with high quality polyester coating and edge moulding, the Italian marble shall be pasted on 18mm thick BWP plywood having 100x25mm section wood framing all around made of sheesham wood. Legs dia 50mm at the top and tapering down to dia 30mm at the bottom, apron section 50x25mm, leg support cross members section 45x25mm made of solid sheesham wood. The legs shall have Stainless Steel end caps which are PVD coated in gold finish. Wood carving and other details to be followed as per reference detailed drawing. Superior quality kiln dried sheesham wood having moisture content not more than 12% and processed with anti-termite treatment in a pressurized chamber to be used. All wood frames/legs/panels shall be joined together using precise mortise & tenon joinery with high quality D3 grade wood glue. All wood surface shall be finished in approved shade of polish with 03 coats of polyurethane lacquer in satin finish with prior sanding, sealing with fillers and polyurethane sealer. All complete as per detailed drawing and directions of officer in-charge.	pcs.	4	REFER DRAWING NO. 12
13.	Side Table : Supply and installation of Side Table size 550Dia x 550mm made of solid sheesham wood / plywood /stone top. Top shall have 18mm thick Italian marble with high quality polyester coating and edge moulding, the Italian marble shall be pasted on 18mm thick BWP plywood having 75x25mm section wood framing all around made of sheesham wood. Legs dia 50mm at the top and tapering down to dia 30mm at the bottom, apron section 50x25mm, leg support cross members section 45x25mm made of solid sheesham wood. The legs shall have Stainless Steel end caps which are PVD coated in gold finish. Wood carving and other details to be followed as per reference detailed drawing. Superior quality kiln dried sheesham wood having moisture content not more than 12% and processed with anti-termite treatment in a pressurized chamber to be used. All wood frames/legs/panels shall be joined together using precise mortise & tenon joinery with high quality D3 grade wood glue. All wood surface shall be finished in approved	pcs.	6	REFER DRAWING NO. 13

	shade of polish with 03 coats of polyurethane lacquer in satin finish with prior sanding, sealing with fillers and polyurethane sealer. All complete as per detailed drawing and directions of officer in-charge.			
14.	Dining Table : Supply and installation of Dining Table size 2400x1050x750mm made of solid sheesham wood / plywood/ stone top. Top thickness 36mm made of 18mm thick Italian marble with high quality polyester coating and 18mm thick edge moulding, the Italian marble shall be pasted on 18mm thick BWP plywood. Legs wood section 80x80mm at the top and tapering down to section 48x48mm at the bottom, table apron section 90x38mm, additional support cross members 03 nos. under the top of wood section 60x25mm made of solid sheesham wood. Wood carving and other details to be followed as per reference detailed drawing. Superior quality kiln dried sheesham wood having moisture content not more than 12% and processed with anti-termite treatment in a pressurized chamber to be used. All wood frames/legs/panels shall be joined together using precise mortise & tenon joinery with high quality D3 grade wood glue. All wood surface shall be finished in approved shade of polish with 03 coats of polyurethane lacquer in satin finish with prior sanding, sealing with fillers and polyurethane sealer. All complete as per detailed drawing and directions of officer in-charge.	pcs.	2	REFER DRAWING NO. 14
15.	Chair : Supply and installation of Chair size 500x580x1030 mm made of solid sheesham wood / upholstery work. Sheesham wood front legs section 50x50 mm tapered to 30x30 mm at the bottom, curved back legs section 35x35mm at the center gradually tapering down to 30x30mm at the top & bottom, chair seat apron section 60x25mm (front/back/side), chair back horizontal panels wood section 35x30mm made of sheesham wood. Chair seat & back to have 12mm thick BWP plywood base upholstered using 50mm thick 40 density PU foam covered with good quality fabric of approved brand costing approx. 800 per meter. Wood carving and other details to be followed as per reference detailed drawing. Superior quality kiln dried sheesham wood having moisture content not more than 12% and processed with anti-termite treatment in a pressurized chamber to be used. All wood frames/legs/panels shall be joined together using precise mortise & tenon joinery with high quality D3 grade wood glue. All wood surface shall be finished in approved shade of polish with 03 coats of polyurethane lacquer in satin finish with prior sanding, sealing with fillers and polyurethane sealer. All complete as per detailed drawing and directions of officer in-charge.	pcs.	12	REFER DRAWING NO. 15
16.	Sideboard : Supply and installation of Sideboard size 2100x450x750mm made of solid sheesham wood / plywood/ sheesham veneer/ stone top. Top thickness 36mm made of 18mm thick Italian marble with high quality polyester coating and 18mm thick edge moulding, the Italian marble shall be pasted on 18mm thick BWP plywood. Legs wood section 50x50mm, horizontal frames at front/side/back of wood section 40x25mm, vertical frames section 30x25mm made of sheesham wood. 02 nos. storage compartment with double leaf shutters made of 40x25mm section sheesham wood with 18mm thick plywood panel pasted with sheesham veneer. Each storage compartment shall have 01 nos. shelf made of 18mm thick BWP plywood sheesham veneer pasting. The sideboard shall have 03 nos. of drawer for storage having front raised panel design. Drawer front panel made of sheesham wood section 170x25mm, drawer side/back panels made of 18mm thick BWP plywood with sheesham veneer pasting and edges covered with 8mm thick sheesham wood lipping & drawer base in 9mm thick BWP plywood with sheesham veneer pasting. Good quality telescopic channel & handle in antique finish, hinges etc. of approved design & brand to be provided for drawer & shutters. Wood carving and other	pcs.	2	REFER DRAWING NO. 16

	<p>details to be followed as per reference detailed drawing. Superior quality kiln dried sheesham wood having moisture content not more than 12% and processed with anti-termite treatment in a pressurized chamber to be used. All wood frames/legs/panels shall be joined together using precise mortise & tenon joinery with high quality D3 grade wood glue. All wood surface shall be finished in approved shade of polish with 03 coats of polyurethane lacquer in satin finish with prior sanding, sealing with fillers and polyurethane sealer. All complete as per detailed drawing and directions of officer in-charge.</p>			
17.	<p>Bed : Supply and installation of Bed size 1890x2100x1260mm made of solid sheesham wood to accommodate mattress size 72"x78". Bed headboard size 1890x60x1260mm made of sheesham wood having legs section 60x60mm, horizontal /vertical frame section 70x25mm, bottom horizontal frames section 230x18mm made of sheesham wood. Bed headboard panels shall be made of sheesham veneer pasted on 18mm thick BWP plywood. Bed footboard size 1890x60x710mm made of solid sheesham wood legs section 60x60mm, horizontal /vertical frame section 70x25mm, bottom horizontal frames section 150x25mm made of sheesham wood. Bed footboard panels shall be made of sheesham veneer pasted on 18mm thick BWP plywood. Bed side rails made of solid sheesham wood section 150x25mm. The bed shall have 18mm thick BWP plywood top to place the mattress which is supported with 01 no. of sheesham wood panel of section 130x28mm & 04 nos. sheesham wood panel of section 80x28mm and 20x18mm battens to place the plywood. A slot of 72"x78" to be provided for the mattress. Wood carving on headboard & footboard and other details to be followed as per reference detailed drawing. Superior quality kiln dried sheesham wood having moisture content not more than 12% and processed with anti-termite treatment in a pressurized chamber to be used. All wood frames/legs/panels shall be joined together using precise mortise & tenon joinery with high quality D3 grade wood glue. All wood surface shall be finished in approved shade of polish with 03 coats of polyurethane lacquer in satin finish with prior sanding, sealing with fillers and polyurethane sealer. All complete as per detailed drawing and directions of officer in-charge.</p>	pcs.	5	REFER DRAWING NO. 17
18.	<p>Bed : Supply and installation of Bed size 974x2100x1260mm made of solid sheesham wood / sheesham veneer / plywood to accommodate mattress size 36"x78". Bed headboard size 974x60x1260mm made of sheesham wood having legs section 60x60mm, horizontal /vertical frame section 70x25mm, bottom horizontal frames section 230x18mm made of sheesham wood. Bed headboard panels shall be made of sheesham veneer pasted on 18mm thick BWP plywood. Bed footboard size 974x60x710mm made of solid sheesham wood legs section 60x60mm, horizontal /vertical frame section 70x25mm, bottom horizontal frames section 150x25mm made of sheesham wood. Bed footboard panels shall be made of sheesham veneer pasted on 18mm thick BWP plywood. Bed side rails made of solid sheesham wood section 150x25mm. The bed shall have 12mm thick BWP plywood top to place the mattress which is supported with 02 nos. sheesham wood panel of section 70x30mm and 20x18mm battens to place the plywood. A slot of 36"x78" to be provided for the mattress. Wood carving on headboard & footboard and other details to be followed as per reference detailed drawing. Superior quality kiln dried sheesham wood having moisture content not more than 12% and processed with anti-termite treatment in a pressurized chamber to be used. All wood frames/legs/panels shall be joined together using precise mortise & tenon joinery with high quality D3 grade wood glue. All wood surface shall be finished in approved shade of polish with 03 coats of polyurethane lacquer in satin finish with prior sanding.</p>	pcs.	10	REFER DRAWING NO. 18

	sealing with fillers and polyurethane sealer. All complete as per detailed drawing and directions of officer in-charge.			
19.	Bedside Cabinet : Supply and installation of Bedside Cabinet size 500x400x600mm made of solid sheesham wood / sheesham veneer/ plywood /stone top. Cabinet top shall have 18mm thick Italian marble with high quality polyester coating and edge moulding, the Italian marble shall be pasted on 18mm thick BWP plywood and covered with 53x18mm sheesham wood molding on all edges. Legs section 38x38mm, horizontal frames at front/side/back section 40x25mm/30x25 made of solid sheesham wood. Cabinet side panels shall be made from sheesham veneer pasted on 12mm thick BWP plywood. The cabinet shall have 01 nos. of drawer for storage having front raised panel design. Drawer front panel made of sheesham wood section 120x25mm, drawer side/back panels made of 18mm thick BWP plywood with sheesham veneer pasting and edges covered with 8mm thick sheesham wood lipping & drawer base in 9mm thick BWP plywood with sheesham veneer pasting. Good quality telescopic channel & handle in antique finish of approved design & brand to be provided for drawer. Wood carving and other details to be followed as per reference detailed drawing. Superior quality kiln dried sheesham wood having moisture content not more than 12% and processed with anti-termite treatment in a pressurized chamber to be used. All wood frames/legs/panels shall be joined together using precise mortise & tenon joinery with high quality D3 grade wood glue. All wood surface shall be finished in approved shade of polish with 03 coats of polyurethane lacquer in satin finish with prior sanding, sealing with fillers and polyurethane sealer. All complete as per detailed drawing and directions of officer in-charge.	pcs.	17	REFER DRAWING NO. 19
20.	Writing Desk : Supply and installation of Writing Desk size 1200x550x770mm made of solid sheesham wood / sheesham veneer/ plywood /stone top. Top shall have 18mm thick Italian marble with high quality polyester coating and edge moulding, the Italian marble shall be pasted on 18mm thick BWP plywood. Table side panels /back panels thickness 22mm, front panel thickness 22mm, legs dia 60mm at the top and tapered to dia 30mm at the bottom made of sheesham wood. Drawer front panel made of sheesham wood section 102x22mm, drawer side/back panels made of 18mm thick BWP plywood with sheesham veneer pasting and edges covered with 8mm thick sheesham wood lipping & drawer base in 9mm thick BWP plywood with sheesham veneer pasting. Good quality telescopic channel of approved design & brand to be provided for drawer. Wood carving and other details to be followed as per reference detailed drawing. Superior quality kiln dried sheesham wood having moisture content not more than 12% and processed with anti-termite treatment in a pressurized chamber to be used. All wood frames/legs/panels shall be joined together using precise mortise & tenon joinery with high quality D3 grade wood glue. All wood surface shall be finished in approved shade of polish with 03 coats of polyurethane lacquer in satin finish with prior sanding, sealing with fillers and polyurethane sealer. All complete as per detailed drawing and directions of officer in-charge.	pcs.	8	REFER DRAWING NO. 20
21.	Chair : Supply and installation of Study chair size 450x500x900Hmm made of solid sheesham wood/ plywood/ upholstery work. Sheesham wood front legs section 50x28 mm tapered to 28x30 mm at the bottom, tapered back legs section 50x28mm at the center gradually tapering down to 28x30mm at the top & bottom, chair seat apron section 50x24mm (front& back) / 70x24mm (side), wooden leg support section 50x28mm made of sheesham wood. Curved shape chair back support shall have finished wood	pcs.	8	REFER DRAWING NO. 21

	section 40x18mm made of sheesham wood. Seat & back to have 12mm thick MR plywood base upholstered using 50mm thick 40 density PU foam covered with good quality fabric of approx. Rs 800 per meter of approved brand. Wood carving and other details to be followed as per reference detailed drawing. Superior quality kiln dried sheesham wood having moisture content not more than 12% and processed with anti-termite treatment in a pressurized chamber to be used. All wood frames/legs/panels shall be joined together using precise mortise & tenon joinery with high quality D3 grade wood glue. All wood surface shall be finished in approved shade of polish with 03 coats of polyurethane lacquer in satin finish with prior sanding, sealing with fillers and polyurethane sealer. All complete as per detailed drawing and directions of officer in-charge.			
22.	Table with Fridge Cabinet : Supply and installation of Table with Fridge Cabinet size 1800x550x750mm made of solid sheesham wood / sheesham veneer/ plywood /stone top. Top shall have 18mm thick Italian marble with high quality polyester coating and edge moulding, the Italian marble shall be pasted on 18mm thick BWP plywood and covered with sheesham wood molding on all edges. Legs section 60x60mm, horizontal frames at front/side/back section 100x25mm & 40x25mm made of solid sheesham wood. Side panels shall be made from sheesham veneer pasted on 18mm thick BWP plywood. The cabinet shall have 01 nos. of storage compartment (for mini fridge) made of sheesham veneer pasted on 18mm thick BWP plywood, shutter frames made of 50x25mm section sheesham wood with 20x18mm battens. Drawer front panel made of sheesham wood section 80x25mm, drawer side/back panels made of 18mm thick BWP plywood with sheesham veneer pasting and edges covered with 8mm thick sheesham wood lipping & drawer base in 9mm thick BWP plywood with sheesham veneer pasting. Wood carving and other details to be followed as per reference detailed drawing. Superior quality kiln dried sheesham wood having moisture content not more than 12% and processed with anti-termite treatment in a pressurized chamber to be used. All wood frames/legs/panels shall be joined together using precise mortise & tenon joinery with high quality D3 grade wood glue. All wood surface shall be finished in approved shade of polish with 03 coats of polyurethane lacquer in satin finish with prior sanding, sealing with fillers and polyurethane sealer. All complete as per detailed drawing and directions of officer in-charge.	pcs.	8	REFER DRAWING NO. 22
23.	Sofa Chair : Supply and installation of Sofa Chair size 700x750x800mm made of solid sheesham wood and upholstery work. Seat inner frame and structure made of 100x30mm section hardwood having s-springs & elastic bands and upholstered using PU foam and good quality fabric of approved shade and texture costing approx. Rs. 800 per mtr. Seat foam 120mm thick of density 40kg/m ³ and back foam 75mm thick of density 40kg/m ³ . Chair seat apron section 40x28mm, front legs wood section 50x50mm, curved back legs wood section 50x38mm, armrest wood section 50x38mm, back horizontal frame section 85x25mm made of sheesham wood. Wood carving and other details to be followed as per reference detailed drawing. Superior quality kiln dried sheesham wood having moisture content not more than 12% and processed with anti-termite treatment in a pressurized chamber to be used. All wood frames/legs/panels shall be joined together using precise mortise & tenon joinery with high quality D3 grade wood glue. All wood surface shall be finished in approved shade of polish with 03 coats of polyurethane lacquer in satin finish with prior sanding, sealing with fillers and polyurethane sealer. All complete as per detailed drawing and directions of officer in-charge.	pcs.	18	REFER DRAWING NO. 23

✓

	2101x1034x1750mm made of solid sheesham wood to accommodate mattress size 36"x78". Bed legs section 60x60mm, side mattress rails section 130x25, side rails 40x24mm made of sheesham wood. The bunk bed shall have 12mm thick BWP Plywood top to place the mattress which is supported with 02 nos. wooden support of section 70x25mm and 20x18mm battens to place the plywood. A slot of 36"x78" to be provided for the mattress. The bed shall have one ladder of size 1750x600x50mm made of 50x25mm section MS pipe finished with black powder coating. Carving and other details to be followed as per reference image/detailed drawing. Superior quality kiln dried sheesham wood having moisture content not more than 12% and process with anti-termite treatment in a pressurized chamber to be used. All wood frames/legs/panels shall be joined together using precise mortise & tenon joinery with high quality D3 grade wood glue. All wood surface shall be finished in approved shade with 02 coats of melamine polish in satin finish with prior sanding, sealing with fillers and melamine sealer. All complete as per detailed drawing and directions of officer in-charge.			
28.	Bedside Cabinet : Supply and installation of Bedside Cabinet size 500x400x580mm made of solid sheesham wood / sheesham veneered plywood. Top thickness 18mm made sheesham wood , legs section 38x38mm, front/side/back horizontal frames section 25x28mm, cabinet side/back panels section 120x18mm made of sheesham wood. The cabinet shall have 01 no. drawer for storage having front raised panel design section with 120x28mm made of sheesham wood, drawer side/back panels made with 18mm thick BWP plywood with 12mm thick wood lipping on exposed edges & drawer base in 9mm thick BWP plywood. The cabinet shall have storage rack at the bottom made of 12mm thick plywood with sheesham veneer pasting which is framed with 25x28mm four side wood framing. Good quality telescopic channel & handle in antique finish to be provided for drawer. Carving and other details to be followed as per reference image/detailed drawing. Superior quality kiln dried sheesham wood having moisture content not more than 12% and process with anti-termite treatment in a pressurized chamber to be used. All wood frames/legs/panels shall be joined together using precise mortise & tenon joinery with high quality D3 grade wood glue. All wood surface shall be finished in approved shade with 02 coats of melamine polish in satin finish with prior sanding, sealing with fillers and melamine sealer. All complete as per detailed drawing and directions of officer in-charge.	pcs.	5	REFER DRAWING NO. 28
29.	Sofa 02 Seater : Supply and installation of Sofa 02 seater size 1650x800x770mm made of solid sheesham wood and upholstery work. Seat inner frame and structure made of 70x30mm section hardwood having s-springs & elastic bands and upholstered using PU foam and good quality fabric of approved shade and texture costing approx. Rs. 800 per mtr. Seat foam 150mm thick of density 40kg/m ³ and back/armrest foam 75mm thick of density 40kg/m ³ . Sofa seat apron section 60x25mm, legs wood section 38x38mm made of sheesham wood. Sofa back and armrest shall have vertical stiped quilting design upholstery work along with antique finish decorative tack nails work. Wood carving and other details to be followed as per reference detailed drawing. Superior quality kiln dried sheesham wood having moisture content not more than 12% and processed with anti-termite treatment in a pressurized chamber to be used. All wood frames/legs/panels shall be joined together using precise mortise & tenon joinery with high quality D3 grade wood glue. All wood surface shall be finished in approved shade of polish with 03 coats of polyurethane lacquer in satin finish with prior sanding, sealing with fillers and polyurethane sealer. All complete as per detailed drawing	pcs.	10	REFER DRAWING NO. 29

W

	and directions of officer in-charge.			
30.	Sofa 03 Seater : Supply and installation of Sofa 03 seater size 2250x800x770mm made of solid sheesham wood and upholstery work. Seat inner frame and structure made of 70x30mm section hardwood having s-springs & elastic bands and upholstered using PU foam and good quality fabric of approved shade and texture costing approx. Rs. 800 per mtr. Seat foam 150mm thick of density 40kg/m3 and back/armrest foam 75mm thick of density 40kg/m3. Sofa seat apron section 60x25mm, legs wood section 38x38mm made of sheesham wood. Sofa back and armrest shall have vertical stiped quilting design upholstery work along with antique finish decorative tack nails work. Wood carving and other details to be followed as per reference detailed drawing. Superior quality kiln dried sheesham wood having moisture content not more than 12% and processed with anti-termite treatment in a pressurized chamber to be used. All wood frames/legs/panels shall be joined together using precise mortise & tenon joinery with high quality D3 grade wood glue. All wood surface shall be finished in approved shade of polish with 03 coats of polyurethane lacquer in satin finish with prior sanding, sealing with fillers and polyurethane sealer. All complete as per detailed drawing and directions of officer in-charge.	pcs.	3	REFER DRAWING NO. 30
31.	Centre Table : Supply and installation of Centre Table size 1200x600x450mm made of solid sheesham wood / sheesham veneer / plywood /stone top. Top shall have 18mm thick Italian marble with high quality polyester coating and edge moulding, the Italian marble shall be pasted on 18mm thick BWP plywood having 50x22mm section wood framing all around made of sheesham wood. Legs section 50x50 at the top and tapering down to section 30x30mm at the bottom, apron section 50x25mm, leg support cross members section 30x25mm made of solid sheesham wood. The table shall have storage rack at the bottom made of sheesham veneer pasted on 18mm thick BWP plywood. Wood carving and other details to be followed as per reference detailed drawing. Superior quality kiln dried sheesham wood having moisture content not more than 12% and processed with anti-termite treatment in a pressurized chamber to be used. All wood frames/legs/panels shall be joined together using precise mortise & tenon joinery with high quality D3 grade wood glue. All wood surface shall be finished in approved shade of polish with 03 coats of polyurethane lacquer in satin finish with prior sanding, sealing with fillers and polyurethane sealer. All complete as per detailed drawing and directions of officer in-charge.	pcs.	6	REFER DRAWING NO. 31
32.	Side Table : Supply and installation of Centre Table size 600x600x550mm made of solid sheesham wood / sheesham veneer / plywood /stone top. Top shall have 18mm thick Italian marble with high quality polyester coating and edge moulding, the Italian marble shall be pasted on 18mm thick BWP plywood having 50x22mm section wood framing all around made of sheesham wood. Legs section 50x50 at the top and tapering down to section 30x30mm at the bottom, apron section 50x25mm, leg support cross members section 30x25mm made of solid sheesham wood. The table shall have storage rack at the bottom made of sheesham veneer pasted on 18mm thick BWP plywood. Wood carving and other details to be followed as per reference detailed drawing. Superior quality kiln dried sheesham wood having moisture content not more than 12% and processed with anti-termite treatment in a pressurized chamber to be used. All wood frames/legs/panels shall be joined together using precise mortise & tenon joinery with high quality D3 grade wood glue. All wood surface shall be finished in approved shade of polish with 03 coats of polyurethane lacquer in satin finish with prior sanding, sealing with fillers and polyurethane sealer. All complete as per detailed drawing and directions of	pcs.	2	REFER DRAWING NO. 32

N

	officer in-charge.			
33.	Dining Table : Supply and installation of Dining Table size 1780x1000x750mm made of solid sheesham wood / plywood/ stone top. Top made of 18mm thick marble with high quality polyester coating and edge moulding, the marble shall be pasted on 18mm thick BVVP plywood. Legs wood section 70x70mm at the top and tapering down to section 50x50mm at the bottom, table apron section 80x25mm, additional support cross members 02 nos. under the top of wood section 60x25mm made of solid sheesham wood. Wood carving and other details to be followed as per reference detailed drawing. Superior quality kiln dried sheesham wood having moisture content not more than 12% and processed with anti-termite treatment in a pressurized chamber to be used. All wood frames/legs/panels shall be joined together using precise mortise & tenon joinery with high quality D3 grade wood glue. All wood surface shall be finished in approved shade of polish with 03 coats of polyurethane lacquer in satin finish with prior sanding, sealing with fillers and polyurethane sealer. All complete as per detailed drawing and directions of officer in-charge.	pcs.	21	REFER DRAWING NO. 33
34.	Dining Table : Supply and installation of Dining Table size 1000x1000x750mm made of solid sheesham wood / plywood/ stone top. Top made of 18mm thick marble with high quality polyester coating and edge moulding, the marble shall be pasted on 18mm thick BWVP plywood. Legs wood section 70x70mm at the top and tapering down to section 50x50mm at the bottom, table apron section 80x25mm, additional support cross members 02 nos. under the top of wood section 60x25mm made of solid sheesham wood. Wood carving and other details to be followed as per reference detailed drawing. Superior quality kiln dried sheesham wood having moisture content not more than 12% and processed with anti-termite treatment in a pressurized chamber to be used. All wood frames/legs/panels shall be joined together using precise mortise & tenon joinery with high quality D3 grade wood glue. All wood surfaces shall be finished in approved shade of polish with 03 coats of polyurethane lacquer in satin finish with prior sanding, sealing with fillers and polyurethane sealer. All complete as per detailed drawing and directions of officer in-charge.	pcs.	10	REFER DRAWING NO. 34
35.	Chair : Supply and installation of Study chair size 450x500x900Hmm made of solid sheesham wood/ plywood/ upholstery work. Sheesham wood front legs section 50x50 mm tapered to 35x35 mm at the bottom, tapered back legs section 35x35mm at the center gradually tapering down to 35x30mm at the top & bottom, chair seat apron section 60x24mm (front& back) / 60x24mm (side), wooden leg support section 50x24mm, back rest horizontal frames 60x24mm and vertical battens 20x16mm made of sheesham wood. Seat to have 12mm thick MR plywood base upholstered using 50mm thick 40 density PU foam covered with good quality fabric of approx. Rs 800 per meter of approved brand. Wood carving and other details to be followed as per reference detailed drawing. Superior quality kiln dried sheesham wood having moisture content not more than 12% and processed with anti-termite treatment in a pressurized chamber to be used. All wood frames/legs/panels shall be joined together using precise mortise & tenon joinery with high quality D3 grade wood glue. All wood surface shall be finished in approved shade of polish with 03 coats of polyurethane lacquer in satin finish with prior sanding, sealing with fillers and polyurethane sealer. All complete as per detailed drawing and directions of officer in-charge.	pcs.	166	REFER DRAWING NO. 35
36.	Sideboard : Supply and installation of Sideboard size 2100x450x750mm made of solid sheesham wood / plywood/ sheesham veneer/ stone top. Top made of 18mm	pcs.	2	REFER DRAWING NO. 36

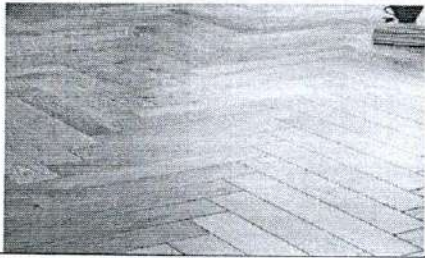

	<p>thick marble with high quality polyester coating and edge moulding, the marble shall be pasted on 18mm thick BWP plywood. Legs wood section 60x60mm, horizontal frames at front/side/back of wood section 33x25mm, vertical frames section 30x25mm made of sheesham wood. 02 nos. storage compartment with double leaf shutters made of 40x25mm section sheesham wood with 18mm thick plywood panel pasted with sheesham veneer. Each storage compartment shall have 01 nos. shelf made of 18mm thick BWP plywood with veneer pasting. The sideboard shall have 03 nos. of drawer for storage, drawer front panel made of sheesham wood section 110x22mm, drawer side/back panels made of 18mm thick BWP plywood with veneer pasting and edges covered with 8mm thick sheesham wood lipping & drawer base in 9mm thick BWP plywood with veneer pasting. Good quality telescopic channel & handle in antique finish, hinges etc. of approved design & brand to be provided for drawer & shutters. Wood carving and other details to be followed as per reference detailed drawing. Superior quality kiln dried sheesham wood having moisture content not more than 12% and processed with anti-termite treatment in a pressurized chamber to be used. All wood frames/legs/panels shall be joined together using precise mortise & tenon joinery with high quality D3 grade wood glue. All wood surface shall be finished in approved shade of polish with 03 coats of polyurethane lacquer in satin finish with prior sanding, sealing with fillers and polyurethane sealer. All complete as per detailed drawing and directions of officer in-charge.</p>			
37.	<p>Mirror with Frame : Supply and installation of Mirror with Frame size 550x25x1700mm made of solid sheesham wood / plywood/ mirror. The mirror shall be made with sheesham wood vertical and horizontal frames of section 65x25mm having a rebate of 10mm at the back. Mirror 4mm thick along with 6mm thick BWP plywood backing shall be provided in the frame. Wood carving and other details to be followed as per reference detailed drawing. Superior quality kiln dried sheesham wood having moisture content not more than 12% and processed with anti-termite treatment in a pressurized chamber to be used. All wood frames/legs/panels shall be joined together using precise mortise & tenon joinery with high quality D3 grade wood glue. All wood surface shall be finished in approved shade of polish with 03 coats of polyurethane lacquer in satin finish with prior sanding, sealing with fillers and polyurethane sealer. All complete as per detailed drawing and directions of officer in-charge.</p>	pcs.	14	REFER DRAWING NO. 37
38.	<p>Wall Paneling : Supply and installation of Wall Paneling made of white ash wood / white ash veneer / plywood. The wall paneling shall be made with white ash wood veneer pasted on 12mm thick BWP plywood along with 50x12mm thick BWP plywood battens which are fixed on the wall horizontal and vertically. Distance between each plywood batten shall not be more than 600mm. 50x10mm section white ash wood molding shall be provided as per drawing to cover joints of plywood/veneer. Superior quality kiln dried wood having moisture content not more than 12% and processed with anti-termite treatment in a pressurized chamber to be used. All wood frames/legs/panels shall be joined together using precise mortise & tenon joinery with high quality D3 grade wood glue. All wood surface shall be finished in approved shade of polish with 03 coats of polyurethane lacquer in satin finish with prior sanding, sealing with fillers and polyurethane sealer. All complete as per detailed drawing and directions of officer in-charge.</p>	Sq. Mtr.	798	REFER DRAWING NO. 38



39.	Wooden Flooring : Supply and installation of oak finish wooden flooring in herringbone pattern AC4 grade along with wooden skirting. The thickness of flooring shall be 8mm with HDF backing. A layer of 3mm thick EPE foam shall be laid under the wooden flooring for protection against moisture. All complete as per detailed drawing and directions of officer in-charge.	Sq. Feet	750	
40.	Curtain With Blackout Lining & Sheer Fabric (84"x108") : Supply and installation of window curtain with blackout lining & sheer fabric of size 84x108 inch. The curtain shall include main fabric which is blend of 45% cotton & 55% polyester along with 60% blackout lining made of 100% polyester fabric. The sheer curtain shall be made of 100% polyester fabric. Good quality fabric/blackout lining/sheer fabric of approved shade and texture each costing approx. Rs. 600 per mtr., to be used. Curtain channels / curtain rods to be provided as per requirement. All complete as per site requirement and directions of officer in-charge.	pcs.	8	N.A.
41.	Blackout Fabric Curtain (66"x108") : Supply and installation of window blackout fabric curtain of size 66"x108 inch. The curtain shall be made of 60% blackout fabric which is 100% polyester. Good quality fabric of approved shade and texture costing approx. Rs. 600 per mtr. to be used. Curtain channels / curtain rods to be provided as per requirement. All complete as per site requirement and directions of officer in-charge.	pcs.	13	N.A.
42.	Roller Blinds (78"x78") : Supply and installation of Roller Blinds with pelmet size 78x78 inch made of texture fabric with black lining. The blinds shall be made of 100% polyester fabric of approved shade and texture. All complete as per site requirement and directions of officer in-charge.	pcs.	4	N.A.
43.	Roller Blinds (60"x78") : Supply and installation of Roller Blinds with pelmet size 60x78 inch made of texture fabric with black lining. The blinds shall be made of 100% polyester fabric of approved shade and texture. All complete as per site requirement and directions of officer in-charge.	pcs.	5	N.A.
44.	Mattress (72"x78"x8") : Supply and installation of mattress size 72"x78"x8". The mattress shall be made of 6" pocket springs with a layer of 1" thick 32 density PU foam on top and bottom. The mattress shall have high quality fabric cover with quilting on all sides of 12mm 32D +125GSM Poly wadding +18GSM non woven fabric. Good quality mattress from approved brand to be provided. All complete as per site requirement and directions of officer in-charge.	pcs.	2	N.A.
45.	Mattress (72"x78"x6") : Supply and installation of mattress size 72"x78"x6". The mattress shall be made of 4" pocket springs with a layer of 1" thick 32 density PU foam on top and bottom. The mattress shall have high quality fabric cover with quilting on all sides of 12mm 32D +125GSM Poly wadding +18GSM non woven fabric. Good quality mattress from approved brand to be provided. All complete as per site requirement and directions of officer in-charge.	pcs.	5	N.A.
46.	Mattress (36"x78"x6") : Supply and installation of mattress size 36"x78"x6". The mattress shall be made of 4" pocket springs with a layer of 1" thick 32 density PU foam on top and bottom. The mattress shall have high quality fabric cover with quilting on all sides of 12mm 32D +125GSM Poly wadding +18GSM non woven fabric. Good quality mattress from approved brand to be provided. All complete as per site requirement and directions of officer in-charge.	pcs.	10	N.A.
47.	Mattress (36"x78"x4") : Supply and installation of mattress size 36"x78"x4". The mattress shall be made with a	pcs.	26	N.A.

	layer of 3" thick re-bonded foam pasted with a layer 1" thick high resilience (H.R.) foam. The mattress shall have high quality knitted fabric cover with quilting on both side. Good quality mattress from approved brand to be provided. All complete as per site requirement and directions of officer in-charge.			
48.	Pillow (17"x27") :Supply of Pillow size 17"x27" filled with Recron hollow 3D conjugate fibre and covered with premium satin-stripe fabric. All complete as per directions of officer in-charge.	pcs.	50	N.A.
49.	Bedsheet (90"x108") : Supply of Bedsheet size 90x108 inch made of premium having 300 thread count. All complete as per directions of officer in-charge.	pcs.	20	N.A.
50.	Bedsheet (60"x108") : Supply of Bedsheet size 60x108 inch made of premium having 300 thread count. All complete as per directions of officer in-charge.	pcs.	40	N.A.
51.	Pillow Cover (18"x28") : Supply of Pillow Cover size 18x28 inch made of premium fabric having 300 thread count. All complete as per directions of officer in-charge.	pcs.	80	N.A.
52.	Quilt /Comforter (90"x100") : Supply of Bed Quilt/Comforter of size 90x100 inch filled with 220 gsm premium virgin microfibre encased in high quality breathable cotton cover. All complete as per directions of officer in-charge.	pcs.	14	N.A.
53.	Quilt /Comforter (60"x100") : Supply of Bed Quilt/Comforter of size 60x100 inch filled with 220 gsm premium virgin microfibre encased in high quality breathable cotton cover. All complete as per directions of officer in-charge.	pcs.	30	N.A.
54.	Quilt Cover (92"x102") : Supply of Quilt Cover of size 92x102 inch made from washable premium fabric having 300 thread count. All complete as per directions of officer in-charge.	pcs.	14	N.A.
55.	Quilt Cover (62"x102") : Supply of Quilt Cover of size 62x102 inch made from washable premium fabric having 300 thread count. All complete as per directions of officer in-charge.	pcs.	30	N.A.
56.	Bed Runner (20"x100") : Supply of Bed Runner size 20x100 inch with premium velvet fabric & quilting design work. All complete as per directions of officer in-charge.	pcs.	14	N.A.
57.	Bed Runner (20"x60") : Supply of Bed Runner size 20x100 inch with premium velvet fabric & quilting design work. All complete as per directions of officer in-charge.	pcs.	20	N.A.
58.	Bath Towel (30"x60") : Supply of Bath Towel size 30x60 inch made with 20's ring spun 100% combed cotton yarn 600gms. All complete as per directions of officer in-charge.	pcs.	40	N.A.
59.	Hand Towel (16"x24") : Supply of Hand Towel size 16x24 inch made with 20's ring spun 100% combed cotton yarn 150gms. All complete as per directions of officer in-charge.	pcs.	40	N.A.
60.	Face Towel (12"x12") : Supply of Hand Towel size 16x24 inch made with 20's ring spun 100% combed cotton yarn. All complete as per directions of officer in-charge.	pcs.	40	N.A.
61.	Bath Matt (20"x30") : Supply of Bath Matt 20x30 inch made with 100% ring spun soft cotton 330gms which is anti-slip. All complete as per directions of officer in-charge.	pcs.	30	N.A.
62.	Carpet (8x5 ft) : Supply of Carpet size 8x5 feet made with 100% wool material having hand tufted weaving in premium design and pile thickness 6-9mm.All complete as per directions of officer in-charge.	pcs.	4	N.A.
63.	Towel Rack : Supply and installation ofTowel Racksize 24 inch (length) made of 304 Grade stainless steel. All complete as per directions of officer in-charge.	pcs.	15	N.A.
64.	Towel Rail : Supply and installation ofTowel Railsize 24 inch (length) made of 304 Grade stainless steel. All complete as per directions of officer in-charge.	pcs.	15	N.A.
65.	Napkin Holder : Supply and installation ofNapkin Holdermade of 304 Grade stainless steel. All complete as per directions of officer in-charge.	pcs.	15	N.A.
66.	Cloth Hanger : Supply and installation ofCloth Hanger size 10 inch (length) with 4 hooksmade of 304 Grade stainless	pcs.	30	N.A.

	steel. All complete as per directions of officer in-charge.			
67.	Grab Bar : Supply and installation of Grab Bar size 12 inch (length) made of 304 Grade stainless steel. All complete as per directions of officer in-charge.	pcs.	12	N.A.
68.	Outdoor Dining Table with 04 Chairs : Supply and installation of Outdoor Dining Table with 04 Chairs. Table made primarily out of 18mm dia MS pipe and plastic wicker material of approved shade. Table of size 600mm Dia X600mm Height with 400mm dia x 10mm thick glass. Chair made primarily out of 18mm dia MS pipe and plastic wicker material of approved shade. Chair of size 600x530x750mm having sitting height from floor 430mm. All complete as per detailed drawing and directions of officer in-charge.	pcs.	10	
69.	Office Desk with Side Unit : Supply and installation of Office Desk 1980x750x750mm with Side Unit of size 1000x450x750mm made of sheesham wood / sheesham veneer / plywood / Stone top. Office desk top made of 18mm thick marble with high quality polyester coating and edge moulding, the marble shall be pasted on 18mm thick BWP plywood. Legs wood section 50x50mm, horizontal frames at front/side/back of wood section 70x25mm/60x25mm, vertical frames section 40x25mm, skirting wood section 114x22mm made of sheesham wood. Side panels and front panels shall have raised panel design made of sheesham veneer pasted on 18mm thick BWP plywood. The office desk shall have 01 nos. pedestal storage cabinet of size 450x400x600mm made of 18mm thick BWP plywood with sheesham veneer. The side unit of size 1000x450x750mm shall be made with 18mm thick BWP plywood pasted with sheesham veneer. The side unit shall have one drawer and storage compartment with shutter. Good quality telescopic channel & handle in antique finish, hinges etc. of approved design & brand to be provided for drawer & shutters. Wood carving and other details to be followed as per reference detailed drawing. Superior quality kiln dried sheesham wood having moisture content not more than 12% and processed with anti-termite treatment in a pressurized chamber to be used. All wood frames/legs/panels shall be joined together using precise mortise & tenon joinery with high quality D3 grade wood glue. All wood surface shall be finished in approved shade of polish with 03 coats of polyurethane lacquer in satin finish with prior sanding, sealing with fillers and polyurethane sealer. All complete as per detailed drawing and directions of officer in-charge.	pcs.	4	REFER DRAWING NO. 39
70.	Office Desk with Side Unit : Supply and installation of Office Desk 1800x750x750mm with Side Unit of size 1000x450x750mm made of plywood and laminate. Office desk & side unit made of 18mm BWP plywood with 1mm thick laminate pasted on the outer surface and 0.8mm thick laminate on the inner surface. The office desk shall have 01 nos. pedestal storage cabinet of size 450x400x700mm made of 18mm thick BWP plywood with laminate pasting. The side unit of size 1000x450x750mm shall be made with 18mm thick BWP plywood pasted with laminate pasting. The side unit shall have one drawer and storage compartment with shutter. Good quality telescopic channel & handle in antique finish, hinges etc. of approved design & brand to be provided for drawer & shutters. Wood carving and other details to be followed as per reference detailed drawing. Superior quality kiln dried sheesham wood having moisture content not more than 12% and processed with anti-termite treatment in a pressurized chamber to be used. All wood frames/legs/panels shall be joined together using precise mortise & tenon joinery with high quality D3 grade wood glue. All wood surface shall be finished in approved shade of polish with 03 coats of polyurethane lacquer in satin finish with prior sanding, sealing with fillers and polyurethane sealer. All complete as per detailed drawing and directions of	pcs.	3	REFER DRAWING NO. 40

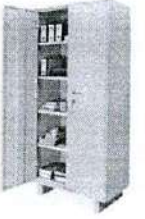

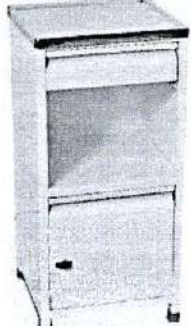
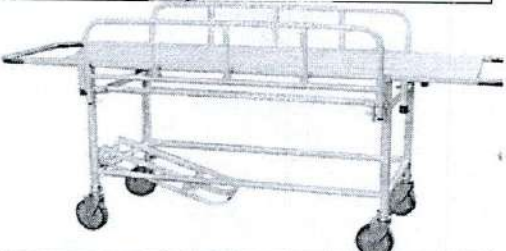

Handwritten signature

	officer in-charge.			
71.	High Back Chair : Supply and installation of high back chair with mesh back. The seating height of the chair ranges from 425mm to 545mm from floor. The seat is made up of 12mm thick hot pressed plywood and upholstered with fabric upholstery covers and moulded polyurethane foam of density 40 kg/m ³ . The mesh back is designed with contoured lumber support for extra comfort. The one piece armrests are injection moulded from black Polypropylene. The mechanism is designed with features such as 360 degree revolving type, upright position locking back, seat / back tilt adjustment. The chair shall have Pneumatic Height adjustment of 100mm. The bellow is 3 piece telescopic type and injection moulded in black polypropylene. The pedestal assembly is injection moulded in black glass filled nylon and fitted with 05 nos. of twin wheel castors which are injection moulded in black nylon. The cost is inclusive of all labour and material etc. complete in all respect as per drawing and direction given by officer in charge. Please refer drawings for more details.	pcs.	9	
72.	Visitor Chair : Supply and installation of visitor chair with mesh back. The seat is made up of 12mm thick hot pressed plywood and upholstered with fabric upholstery covers and moulded polyurethane foam of density 40 kg/m ³ . The mesh back is designed with contoured lumber support for extra comfort. The one piece armrests are injection moulded from black Polypropylene. The tubular frame is cantilever type and made of dia 25mm x 2mm thick M.S. Tube. The cost is inclusive of all labour and material etc. complete in all respect as per drawing and direction given by officer in charge. Please refer drawings for more details.	pcs.	14	
73.	Sofa 03 Seater : Supply and installation of Sofa 03 seater size 1850x800x850mm made of solid sheesham wood and upholstery work. Seat inner frame and structure made of 80x28mm section hardwood having s-springs & elastic bands and upholstered using PU foam and good quality fabric of approved shade and texture costing approx. Rs. 800 per mtr. Seat foam 120mm thick of density 40kg/m ³ and back foam 75mm thick of density 40kg/m ³ . Sofa seat apron section 150x25mm, front legs wood section 80x35mm and back legs wood section 50x35mm made of sheesham wood. Sofa back horizontal frame 80x25mm and armrest wood section 100x25mm. Wood carving and other details to be followed as per reference detailed drawing. Superior quality kiln dried sheesham wood having moisture content not more than 12% and processed with anti-termite treatment in a pressurized chamber to be used. All wood frames/legs/panels shall be joined together using precise mortise & tenon joinery with high quality D3 grade wood glue. All wood surface shall be finished in approved shade of polish with 03 coats of polyurethane lacquer in satin finish with prior sanding, sealing with fillers and polyurethane sealer. All complete as per detailed drawing and directions of officer in-charge.	pcs.	8	REFER DRAWING NO. 41
74.	File Storage Almira : Supply and installation of File Storage Almira of size 900x480x1980mm made of MS CRCA sheet with 04 nos. shelves and locking provision. Door/shelf made of 20 gauge and back top bottom made of 22 gauge sheet. All surface to be powder coated. All complete as per detailed drawing and directions of officer in-charge.	pcs.	16	





75.	Bench 03 Seater : Supply and installation of Bench 03 Seater size 1800x650x800mm (approx.) made of stainless steel. Seat/Back of Bench made in SS 304 grade and arms/legs made in SS 202 grade. All complete as per detailed drawing and directions of officer in-charge.	pcs.	10	
76.	Fowler Position Bed : Supply and installation of Fowler Position Bed size 78"x36"x24" for dispensary with S.S. Panels & Collapsible railing. The Bed shall be provided with a 4" thick Mattress. All complete as per detailed drawing and directions of officer in-charge.	pcs.	3	
77.	Examination Couch : Supply and installation of Hospital Examination Couch size 72"x24"x30" for dispensary . A foot step and a 4" mattress shall be provided with the couch. All complete as per detailed drawing and directions of officer in-charge.	pcs.	2	
78.	Bedside Cabinet : Supply and installation of Hospital Bedside Cabinet size 16"x16"x30" for dispensary having locker with drawer. The cabinet shall be made in MS sheet with powder coating and the top shall be made in stainless steel sheet. All complete as per detailed drawing and directions of officer in-charge.	pcs.	5	
79.	Stretcher Trolley : Supply and installation of Stretcher Trolley size 84x22x32 inchfor dispensary having railing on both sides & a cylinder attachment. The trolley shall have good quality 6" wheels. All complete as per detailed drawing and directions of officer in-charge.	pcs.	1	

80.	Wheel Chair : Supply and installation of Wheel Chair of standard size for dispensary made stainless steel tube structure. The wheel chair shall have a foldable design. All complete as per detailed drawing and directions of officer in-charge.	pcs.	2	
81.	Instrument Trolley : Supply and installation of Instrument Trolley size 24"x18"x 32" for dispensary made of MS frame and base shelf powder coated with four wheels. Top shall be made in S.S. 304 grade with railing. All complete as per detailed drawing and directions of officer in-charge.	pcs.	5	
82.	Medicine Trolley : Supply and installation of Medicine Trolley size 30x18x32 inch for dispensary having 4 drawers for storage. The trolley shall be made of MS frame and base shelf powder coated with four wheels. Top shall be made in S.S. 304 grade with railing. All complete as per detailed drawing and directions of officer in-charge.	pcs.	2	
83.	Bed Side Screen : Supply and installation of Bed Side Screen size 92"x66" for dispensary. The screen shall be made in MS frame powder coated with wheels and shall be three fold type with curtains. All complete as per detailed drawing and directions of officer in-charge.	pcs.	4	



Handwritten signature or mark.

84.	Revolving Stool : Supply and installation of Revolving Stool size 12"x12"x18" for dispensary with foot rest ring having four legs made in MS frame and revolving seat made in stainless steel 304 grade. All complete as per detailed drawing and directions of officer in-charge.	pcs.	5	
85.	Drip Stand : Supply and installation of Drip Stand size 42" height for dispensary made of stainless steel 304 grade with wheels. All complete as per detailed drawing and directions of officer in-charge.	pcs.	5	
86.	Fix Stool : Supply and installation of Fix Stool size 12x12x18 inch for dispensary having stainless steel 304 grade top and MS frame structure powder coated. All complete as per detailed drawing and directions of officer in-charge.	pcs.	5	
87.	Single Foot Step – Supply and installation of Single Foot Step size 16"x12"x10" for dispensary made of MS frame powder coated. All complete as per detailed drawing and directions of officer in-charge.	pcs.	3	

n

88.	Crash Cart : Supply and installation of Crash Cart size 28x14x66 inch for dispensary made of stainless steel 304 grade with wheels. All complete as per detailed drawing and directions of officer in-charge.	pcs.	2	
89.	Bio Waste Trolley : Supply and installation of Bio Waste Trolley size 42"x14"x20" for dispensary made of MS frame. The trolley shall be supplied with 03 nos. of plastic waste bins in three different shades. All complete as per detailed drawing and directions of officer in-charge.	pcs.	2	
90.	Dustbin : Supply and installation Dustin Bin size 12x24 inch made of stainless steel 304 grade.	pcs.	11	
91.	Dustbin : Supply and installation Dustin Bin size 8x16 inch made of stainless steel 304 grade.	pcs.	50	

N

92.	Oxygen Cylinder Trolley : Supply and installation of Oxygen Cylinder Trolley large size D type for dispensary made of MS powder coated frame with wheels.	pcs.	2	
93.	Planters : Supply and installation of Planter having approx. 22" height. The planters shall be made of polymer material which is UV stabilised for non-fading colours for outdoor and indoor use. The planter should have Provision of drainage cap. All complete as per detailed drawing and directions of officer in-charge.	pcs.	25	
94.	Storage Rack : Supply and installation of Storage Rack size 36"x12"x72" made of mild steel. The storage rack shall have 05 nos. shelves for storage and the legs shall be made of slotted mild steel angle all powder coated finish. All complete as per detailed drawing and directions of officer in-charge.	pcs.	11	

2

Annexure-A

Sample to be submitted				
S.No.	Item Name	Drawing No. / Ref. Image No.	Sample to be submitted (Yes/No)	Sample Type
1	Main Entrance Gates	1	YES	Sample Panel of size 48"x48" as per drawing & specification along with required hinges to be submitted.
2	Main Entrance Gates	2	NO	
3	Bed	3	YES	As per drawing & Specification
4	Bedside Cabinet	4	YES	As per drawing & Specification
5	Desk with Fridge Cabinet	5	NO	
6	Chair with Armrest	6	YES	As per drawing & Specification
7	Luggage Table	7	NO	
8	Wardrobe	8	YES	As per drawing & Specification
9	Sofa Chair	9	YES	As per drawing & Specification
10	Sofa 03 Seater	10	NO	
11	Sofa 02 Seater	11	YES	As per drawing & Specification
12	Centre Table	12	YES	As per drawing & Specification
13	Side Table	13	NO	
14	Dining Table	14	NO	
15	Chair	15	NO	
16	Sideboard	16	NO	
17	Bed	17	YES	As per drawing & Specification
18	Bed	18	NO	
19	Bedside Cabinet	19	YES	As per drawing & Specification
20	Writing Desk	20	YES	As per drawing & Specification
21	Chair	21	YES	As per drawing & Specification
22	Table with Fridge Cabinet	22	YES	As per drawing & Specification
23	Sofa Chair	23	YES	As per drawing & Specification

S.No.	Item Name	Drawing No. / Ref. Image No.	Sample to be submitted (Yes/No)	Sample Type
24	Side Table	24	YES	As per drawing & Specification
25	Luggage Table	25	YES	As per drawing & Specification
26	Wardrobe	26	YES	As per drawing & Specification
27	Bunk Bed	27	YES	As per drawing & Specification
28	Bedside Cabinet	28	NO	
29	Sofa 02 Seater	29	YES	As per drawing & Specification
30	Sofa 03 Seater	30	NO	
31	Centre Table	31	YES	As per drawing & Specification
32	Side Table	32	NO	
33	Dining Table	33	YES	As per drawing & Specification
34	Dining Table	34	NO	
35	Chair	35	YES	As per drawing & Specification
36	Sideboard	36	NO	
37	Mirror with Frame	37	YES	As per drawing & Specification
38	Wall Panelling	38	NO	
39	Wooden Flooring	NA	YES	As per drawing & Specification
40	Curtain With Blackout Lining & Sheer Fabric (84"x108")	NA	YES	Fabric Catalogue/Samples to be submitted
41	Blackout Fabric Curtain (66"x108")	NA	YES	Fabric Catalogue/Samples to be submitted
42	Roller Blinds (78"x78")	NA	YES	Fabric Catalogue/Samples to be submitted
43	Roller Blinds (60"x78")	NA	NO	
44	Mattress (72"x78"x8")	NA	NO	
45	Mattress (72"x78"x6")	NA	YES	As per Specification
46	Mattress (36"x78"x6")	NA	NO	
47	Mattress (36"x78"x4")	NA	YES	As per Specification

S.No.	Item Name	Drawing No. / Ref. Image No.	Sample to be submitted (Yes/No)	Sample Type
48	Pillow (17"x27")	NA	YES	As per Specification
49	Bedsheet (90"x108")	NA	YES	As per Specification
50	Bedsheet (60"x108")	NA	NO	
51	Pillow Cover	NA	YES	As per Specification
52	Bed Quilt /Comforter (100"x90")	NA	YES	As per Specification
53	Bed Quilt /Comforter (100"x60")	NA	NO	
54	Quilt Cover (92"x102")	NA	YES	As per Specification
55	Quilt Cover (62"x102")	NA	NO	
56	Bed Runner (20"x100")	NA	YES	As per Specification
57	Bed Runner (20"x60")	NA	NO	
58	Bath Towel (30"x60")	NA	YES	As per Specification
59	Hand Towel (16"x24")	NA	NO	
60	Face Towel (12"x12")	NA	NO	
61	Bath Matt (20"x30")	NA	YES	As per Specification
62	Carpet (8x5 ft)	NA	NO	
63	Towel Rack	NA	YES	As per Specification
64	Towel Rail	NA	YES	As per Specification
65	Napkin Holder	NA	YES	As per Specification
66	Cloth Hanger	NA	YES	As per Specification
67	Grab bar	NA	YES	As per Specification
68	Outdoor Dining Table with 04 Chairs	Attached with Specs.	NO	
69	Office Desk with Side Unit	39	NO	
70	Office Desk with Side Unit	40	NO	
71	High Back Chair	Attached	YES	As per Specification

N

S.No.	Item Name	Drawing No. / Ref. Image No.	Sample to be submitted (Yes/No)	Sample Type
72	Visitor Chair	Attached with Specs.	YES	As per Specification
73	Sofa 03 Seater	41	YES	As per Specification
74	File/ Storage Almira	Attached with Specs.	NO	
75	Bench 03 Seater (S.S.)	Attached with Specs.	NO	
76	Fowler Position Bed	Attached with Specs.	NO	
77	Examination Couch	Attached with Specs.	NO	
78	Bedside Cabinet	Attached with Specs.	NO	
79	Stretcher Trolley	Attached with Specs.	NO	
80	WHEEL CHAIR	Attached with Specs.	NO	
81	Instrument Trolley	Attached with Specs.	NO	
82	Medicine Trolley	Attached with Specs.	NO	
83	Bed Side Screen	Attached with Specs.	NO	
84	Revolving Stool	Attached with Specs.	NO	
85	Drip Stand	Attached with Specs.	NO	
86	Fix Stool	Attached with Specs.	NO	
87	Single Foot Step	Attached with Specs.	NO	

W

88	Crash Cart	Attached with Specs.	NO	
S.No.	Item Name	Drawing No. / Ref. Image No.	Sample to be submitted (Yes/No)	Sample Type
89	Bio waste Trolley	Attached with Specs.	NO	
90	Dustbin (12x24")	Attached with Specs.	NO	
91	Dustbin (8x16")	Attached with Specs.	NO	
92	Oxygen Cylinder trolley	Attached with Specs.	NO	
93	Planters	Attached with Specs.	NO	
94	Storage Rack	Attached with Specs.	NO	

W

Annexure - B

सत्यनिष्ठा की संहिता

उपापन प्रक्रिया में भाग लेने वाला कोई भी व्यक्ति या फर्म, -

- (क) उपापन प्रक्रिया में अनुचित फायदे के लिए या अन्यथा उपापन प्रक्रिया को प्रभावित करने की एवज में किसी रिश्त, इनाम या दान या प्रत्यक्ष रूप से या अप्रत्यक्ष रूप से किसी तात्त्विक फायदे का कोई प्रस्ताव नहीं करेगा;
- (ख) सूचना का ऐसा दुर्व्यपदेशन या लोप नहीं करेगा जो किसी वित्तीय या अन्य फायदा अभिप्राप्त करने के लिए या किसी बाध्यता से प्रविरत रहने के लिए गुमराह करता हो या गुमराह करने का प्रयास करता हो;
- (ग) उपापन प्रक्रिया की पारदर्शिता, निष्पक्षता और प्रगति को बाधित करने के लिए किसी भी दुरभिसंधि, बोली में कूट मूल्य वृद्धि या प्रतियोगिता विरोधी आचरण में लिप्त नहीं होगा;
- (घ) उपापन संस्था और बोली लगाने वालों के बीच साझा की गयी किसी भी जानकारी का उपापन प्रक्रिया में अनुचित लाभ प्राप्त करने के आशय से दुरुपयोग नहीं करेगा;
- (ङ) उपापन प्रक्रिया को प्रभावित करने के लिए किसी भी पक्षकार को या उसकी सम्पति को प्रत्यक्ष या अप्रत्यक्ष रूप से क्षति या नुकसान पहुंचाने, ऐसा करने के लिए धमकाने सहित किसी भी प्रपीडन में लिप्त नहीं होगा;
- (च) उपापन प्रक्रिया के किसी भी अन्वेषण या लेखापरीक्षा में बाधा नहीं डालेगा;
- (छ) हित का विरोध, यदि कोई हो, प्रकट करेगा;
- (ज) पिछले तीन वर्षों के दौरान भारत या किसी अन्य देश में किसी भी संस्था के साथ किसी पूर्व नियमभंग को या किसी अन्य उपापन संस्था द्वारा किसी विवर्जन को प्रकट करेगा; हित का विरोध

हित का विरोध

कोई बोली लगाने वाला किसी उपापन प्रक्रिया में एक या अधिक पक्षकारों के साथ हित के विरोध में माना जायेगा जिसमें निम्नलिखित स्थितियां सम्मिलित हैं किन्तु इन तक सीमित नहीं है यदि,-

- (क) उनके समान नियंत्रक भागीदार है;
- (ख) वे उनमें से किसी से, कोई भी प्रत्यक्ष या अप्रत्यक्ष सहायिकी प्राप्त करते हैं या प्राप्त की है;
- (ग) उनका उस बोली के प्रयोजनों के लिए एक ही विधिक प्रतिनिधि है ;

N

- (घ) उनका प्रत्यक्ष रूप से या समान तृतीय पक्षकारों के माफत एक दूसरे के साथ ऐसा संबंध है जो दूसरे की बोली के बारे में सूचना तक पहुंचने या दूसरे की बोली पर प्रभाव डालने की स्थिति रखता हो;
- (ङ) कोई बोली लगाने वाला एक ही बोली प्रक्रिया में एक से अधिक बोली में भाग लेता है। तथापि, यह एक ही उपसंविदाकार को एक से अधिक बोली में सम्मिलित होने से सीमित नहीं करता है जो बोली लगाने वाले के रूप में अन्यथा भाग नहीं लेता है;
- (च) बोली लगाने वाले या उससे सहबद्ध किन्हीं व्यक्तियों ने बोली प्रक्रिया के उपापन की विषयवस्तु के डिजाइन या तकनीकी विनिर्देशों को तैयार करने में सलाहकार के रूप में भाग लिया है। सभी बोली लगाने वाले अर्हता कसौटी और बोली प्ररूपों में यह विवरण उपलब्ध करायेंगे कि बोली लगाने वाला उस सलाहकार या किसी भी अन्य संस्था, जिसने उपापन की विषयवस्तु के लिए डिजाईन, विनिर्देश और अन्य दस्तावेज तैयार किये हैं, के साथ प्रत्यक्ष या अप्रत्यक्ष रूप में न तो संबद्ध है और नहीं संबद्ध रहा है या संविदा के लिए परियोजना प्रबन्धक के रूप में प्रस्तावित किया जा रहा है।

निविदादाता के हस्ताक्षर

M

Annexure - C

निविदादाता द्वारा दिया जाने वाला घोषणा पत्र

आप द्वारा आमंत्रित निविदा क्रमांक.....दिनांक.....के तहत मेरे/हमारे द्वारा प्रस्तुत निविदा के संदर्भ में हम राजस्थान लोक उपापन पारदर्शीता अधिनियम, 2012 के खंड 7 के अंतर्गत यह घोषणा करते हैं कि

01. मैं/हम निविदा दस्तावेजों के अनुसार वांछित अनुभव, तकनीकी, वित्तीय, प्रबंधकीय संसाधन की सक्षमता रखते हैं ।
02. मैं/हम निविदा अनुसार केन्द्र/राज्य सरकार/अन्य स्थानीय अधिकार को कर चुकाने बाबत दायित्व लेते हैं ।
03. मैं/हम ना ही दिवालिया घोषित किया गया है, तथा ना ही मेरी/हमारी फर्म के विरुद्ध न्यायालय/न्यायिक अधिकारी द्वारा कोई वैधानिक कार्यवाही प्रक्रियाधीन है ।
04. मैं/हम तथा हमारे निदेशक/अधिकारियों द्वारा निविदा प्रक्रिया के दौरान गत तीन वर्षों में किसी प्रकार का कोई अपराध संबंधी मामला दर्ज नहीं है तथा किसी भी निविदा प्रक्रिया से निष्कासित नहीं किया गया है ।
05. मैं/हमारे द्वारा अधिनियम, नियमों के संदर्भ में किसी प्रकार के हित का कोई विरोध नहीं है जो कि उचित प्रतियोगिता को प्रभावित करता हो ।

स्थान :

तारीख :

निविदादाता के हस्ताक्षर

M

Annexure - D

निविदा प्रक्रिया के दौरान शिकायत निवारण

प्रथम अपील अधिकारी का पद एवं पता.....कुलसचिव पंडित दीनदयाल उपाध्याय शेखावाटी विश्वविद्यालय,
सीकर

द्वितीय अपील अधिकारी का पद एवं पता.....कुलपति पंडित दीनदयाल उपाध्याय शेखावाटी विश्वविद्यालय,
सीकर

1. यदि कोई बोली लगाने वाला या भावी बोली लगाने वाला इस बात से व्यथित है कि उपापन संस्था कोई निर्णय, कार्यवाही या लोप इस अधिनियम या इसके अधीन जारी नियमों या मार्गदर्शनों के उपबंधों के उल्लंघन में है तो वह उपापन संस्था के ऐसे अधिकारी को, जिसे इस प्रयोजन के लिये पदभिहित किये जाये, विनिर्दिष्ट आधार, जिस पर या जिन पर वह व्यथित है, स्पष्ट रूप से देते हुये, ऐसे विनिश्चय या कार्यवाही या, यथास्थिति, लोप की तारीख से 10 दिन की अवधि या ऐसी अन्य अवधि, जो पूर्व –अर्हता दस्तावेजो या बोली लगाने वाले के रजिस्ट्रीकरण दस्तावेजों या बोली दस्तावेजों में विनिर्दिष्ट की जाये, के भीतर अपील दाखिल कर सकेगा:

परन्तु धारा 27 के निबन्धनों में बोली लगाने वाले के सफल होने की घोषणा के पश्चात अपील केवल उस बोली लगाने वाले द्वारा दाखिल की जा सकेगी जिसने उपापन कार्यवाहीयों में भाग लिया है:

परन्तु यह और की ऐसी दशा में उपापन संस्था वितिय बोली को खोलन से पूर्व तकनीकी बोली का मुल्यांकन करती है, वहा वितिय बोली के मामले से संबंधित अपील केवल उस बोली लगाने वाले के द्वारा दाखिल की जा सकेगी जिसकी तकनीकी बोली स्वीकार्य होने वाली पायी जाती है ।

1. अधिकारी, जिसके समक्ष उपधारा – 1 के अधीन अपील दाखिल की गयी, है अपील पर यथासंभव शीघ्र विचार करेगा और अपील दाखिल करने की तारीख से 30 दिवस के भीतर इसे निपटाने का प्रयास करेगा ।
2. यदि उपधारा 01 के अधीन पदभिहित अधिकारी उपधारा 3 में विनिर्दिष्ट अवधि के भीतर उक्त उपधारा के अधीन दाखिल अपील को निपटाने में असफल हो जाता है या यदि बोली लगाने वाला या भावी बोली लगाने वाला या उपापन संस्था उपधारा 2 के अधीन पारित आदेश से व्यथित है तो बोली लगाने वाला या, या भावी बोली लगाने वाला या यथास्थिति उपापन संस्था, उपधारा 3 में विनिर्दिष्ट अवधि के आवासन से या, यथास्थिति उपधारा 2 के अधीन पारित आदेश की प्राप्ति की तारीख से 15 दिवस के भीतर राज्य सरकार द्वारा इस निमित्त पदभिहित किसी अधिकारी या प्राधिकारी को द्वितीय अपील दाखिल कर सकेगा ।
3. धारा 38 के अधीन उपापन संस्था के निम्नलिखित मामलो से संबंधित किसी विनिश्चय के विरुद्ध कोई अपील नहीं होगा ।

अर्थात:

- क: उपापन की आवश्यकता का अवधारण
ख बोली प्रक्रिया में बोली लगाने वालों के भाग लेने को सीमित करने वाले उपबंध
ग. यह विनिश्चय की निबंधनों में बातचीत की जाये या नहीं
घ. निबन्धनों में उपापन प्रक्रिया का रद्दकरण
ङ. गोपनीयता के उपबंधों का लागू होना ।

4. **अपील का प्रारूप.**— (1) धारा 38 की उप-धारा (1) या (4) के अधीन कोई अपील प्ररूप में उतनी प्रतियों के साथ होगी जितने कि अपील में प्रत्यर्थी हैं।
(2) प्रत्येक अपील उस आदेश, जिसके विरुद्ध अपील की गयी है, यदि कोई हो, अपील में कथित तथ्यों को सत्यापित करने वाले शपथ पत्र और फीस के संदाय के सबूत के साथ होगी।
(3) प्रत्येक अपील प्रथम अपील प्राधिकारी या, यथास्थिति, द्वितीय अपील प्राधिकारी को व्यक्तिशः या रजिस्ट्रीकृत डाक द्वारा या प्राधिकृत प्रतिनिधि के माध्यम से प्रस्तुत की जा सकेगी।
5. **अपील फाइल करने के लिए फीस.**—
(1) प्रथम अपील के लिए फीस दो हजार पांच सौ रुपये और द्वितीय अपील के लिए दस हजार रुपये होगी जो अप्रतिदेय होगी।
(2) फीस का संदाय किसी अधिसूचित बैंक के बैंक मांगदेय ड्राफ्ट या बैंकर चैक के रूप में किया जायेगा जो संबंधित अपील प्राधिकारी के नाम देय होगा।
6. **अपील के निपटारे की प्रक्रिया.**—
(1) प्रथम अपील प्राधिकारी या, यथास्थिति, द्वितीय अपील प्राधिकारी अपील फाइल किये जाने पर प्रत्यर्थी को अपील, शपथ पत्र और दस्तावेजों, यदि कोई हो, की प्रति के साथ नोटिस जारी करेगा और सुनवाई की तारीख नियत करेगा।
(2) सुनवाई के लिए नियत तारीख को प्रथम अपील प्राधिकारी या, यथास्थिति, द्वितीय अपील प्राधिकारी,—
(क) उसके समक्ष उपस्थित अपील के समस्त पक्षकारों की सुनवाई करेगा; और
(ख) मामले से संबंधित दस्तावेजों, सुसंगत अभिलेख या उनकी प्रतियों का अवलोकन या निरीक्षण करेगा।
(3) पक्षकारों की सुनवाई, मामले से संबंधित दस्तावेजों, सुसंगत अभिलेख या उनकी प्रतियों के अवलोकन या निरीक्षण के पश्चात्, संबंधित अपील प्राधिकारी लिखित में आदेश जारी करेगा और अपील के पक्षकारों को उक्त आदेश की प्रति निःशुल्क उपलब्ध करायेगा।
(4) उप नियम (3) के अधीन पारित आदेश राज्य लोक उपापन पोर्टल पर भी दर्शित किया जायेगा।

निविदादाता के हस्ताक्षर

प्ररूप सं. 1

(नियम 83 देखिए)

राजस्थान लोक उपापन में पारदर्शिता अधिनियम, 2012 के अधीन अपील
का ज्ञापन

..... की अपील सं.

(प्रथम/द्वितीय अपील प्राधिकारी) के समक्ष

1. अपीलार्थी की विशिष्टियां :

(i) अपीलार्थी का नाम :

(ii) कार्यालय का पता, यदि कोई हो :

(iii) आवासिक पता :

2. प्रत्यर्थी (प्रत्यर्थियों) का नाम और पता :

(i)

(ii) .

(iii)

3. आदेश का संख्यांक और तारीख जिसके

विरुद्ध अपील की गयी है और

अधिकारी/प्राधिकारी का नाम और पदनाम,

जिसने आदेश पारित किया है, (प्रतिलिपि

संलग्न करें) या अधिनियम के उपबंधों के

उल्लंघन में उपापन संस्था के किसी

✓

विनिश्चय, कार्य या लोप का विवरण जिससे

अपीलार्थी व्यथित है :

4. यदि अपीलार्थी किसी प्रतिनिधि द्वारा

प्रतिनिधित्व किये जाने के लिए प्रस्ताव करता

है तो प्रतिनिधि का नाम और डाक का पता :

5. अपील के साथ संलग्न किये गये शपथपत्रों

और दस्तावेजों की संख्या :

6. अपील का आधार :

.....
.....
.....

. (शपथपत्र द्वारा समर्थित)

भाग 4 (ग) राजस्थान राज-पत्र, जनवरी 24, 2013 155(69)

7. प्रार्थना :

.....
.....

स्थान :

तारीख :

अपीलार्थी के हस्ताक्षर

✓

Annexure - E

निविदा की अतिरिक्त शर्तें

1. वित्तीय बोलियों में अंकगणितीय त्रुटियों का सुधार

बोली मूल्यांकन समिति निम्नलिखित आधार पर, सारभूत रूप से प्रत्युत्तरदायी बोलियों में अंकगणितीय त्रुटियों का सुधार करेगी, अर्थात् :-

- (क) इकाई मूल्य और कुल मूल्य, जो इकाई मूल्य और मात्रा को गुणा करने पर प्राप्त होता है के मध्य यदि कोई विसंगति हो तो इकाई मूल्य अभिभावी होगा और कुल मूल्य में सुधार किया जायेगा, जब तक कि बोली मूल्यांकन समिति की राय में इकाई मूल्य में दशमलव बिन्दु की स्थिति में स्पष्ट गलती रह गयी है, ऐसे मामले में उत्कथित कुल मूल्य प्रभावी होगा और इकाई मूल्य में सुधार किया जायेगा ;
- (ख) यदि योग के घटकों को जोड़ने या घटाने के कारण योग में त्रुटि रह गयी है तो घटक अभिभावी होंगे योग में सुधार किया जायेगा ; और
- (ग) यदि शब्दों और अंकों के मध्य कोई विसंगति है तो शब्दों में व्यक्त की गयी रकम तब तक अभिभावी होगी जब तक कि शब्दों में अभिव्यक्त रकम कोई अंकगणितीय त्रुटि से संबंधित न हो, ऐसे मामले में उपर्युक्त खण्ड (क) और (ख) के अध्यधीन रहते हुए अंकों में अभिव्यक्त रकम अभिभावी होगी।

- #### 2. किसी या समस्त बोलियों को स्वीकार या अस्वीकार करने का उपापन संस्था का अधिकार.— उपापन संस्था बोली लगाने वालों के प्रति किसी उत्तरदायित्व को उपगत किये बिना, किसी बोली को स्वीकार या अस्वीकार करने, और बोली प्रक्रिया को रद्द करने और संविदा के अधिनिर्णय से पूर्व किसी भी समय, समस्त बोलियों को अस्वीकार करने का अधिकार सुरक्षित रखती है। ऐसा करने के कारण लेखबद्ध किये जायेंगे।

परिमाण में परिवर्तन का अधिकार.—

- (1) संविदा के अधिनिर्णय के समय, बोली दस्तावेजों में मूलतः विनिर्दिष्ट माल, संकर्मों या सेवाओं के परिमाण में बढ़ोतरी की जा सकेगी, किन्तु ऐसी बढ़ोतरी बोली दस्तावेजों में विनिर्दिष्ट परिमाण के बीस प्रतिशत से

अधिक नहीं होगी। यह बोली और बोली दस्तावेजों के इकाई मूल्यों या अन्य निबंधनों और शर्तों में किसी परिवर्तन के बिना होगी।

- (2) यदि उपापन संस्था परिस्थितियों में परिवर्तन के कारण उपापन की कोई विषयवस्तु उपाप्त नहीं करती है या बोली दस्तावेजों में विनिर्दिष्ट परिमाण से कम उपाप्त करती है तो बोली लगाने वाला बोली दस्तावेजों में अन्यथा उपबंधित के सिवाय, किसी भी दावे या प्रतिकर का हकदार नहीं होगा।
- (3) अतिरिक्त मदों या अतिरिक्त परिमाणों के लिए पुनरादेश, यदि यह बोली दस्तावेजों में उपबंधित हो, निविदा में दी गयी दरों और शर्तों पर दिये जा सकेंगे यदि मूल आदेश खुली प्रतियोगी बोलियां आमंत्रित करने के पश्चात् दिया गया था। प्रदाय या पूर्ण होने की कालावधि भी आनुपातिक रूप से बढ़ायी जा सकेगी। पुनरादेश की सीमाएं निम्नलिखित होंगी –
- (क) संकर्मों की दशा में व्यष्टिक मदों की मात्रा का 50 प्रतिशत और मूल संविदा के मूल्य का 20 प्रतिशत और
- (ख) मूल संविदा के माल या सेवाओं के मूल्य का 25 प्रतिशत।

निविदादाता के हस्ताक्षर मय सील

Drawing No. : 1
 Item : Main Entrance Gates

FRONT / BACK ELEVATION

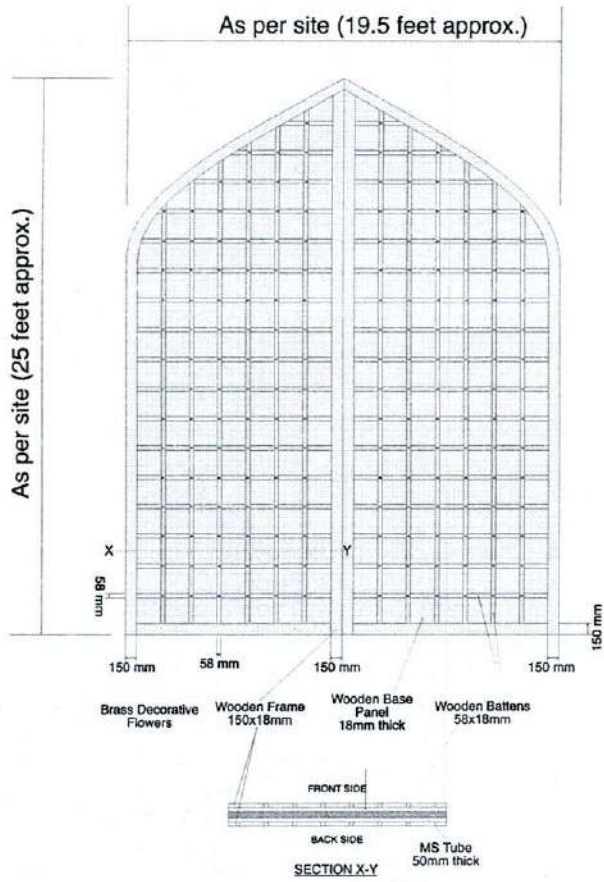

INNER M.S. FRAME DETAIL

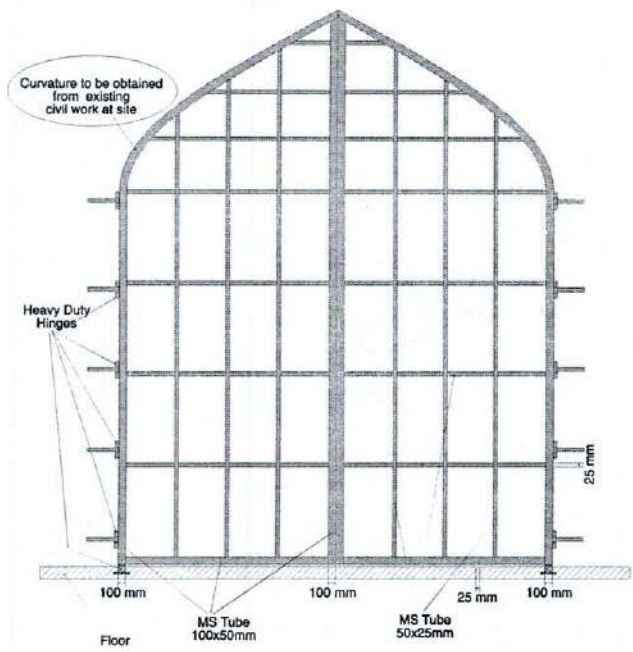

N

Drawing No. : 2
 Item : Main Entrance Gates

FRONT / BACK ELEVATION

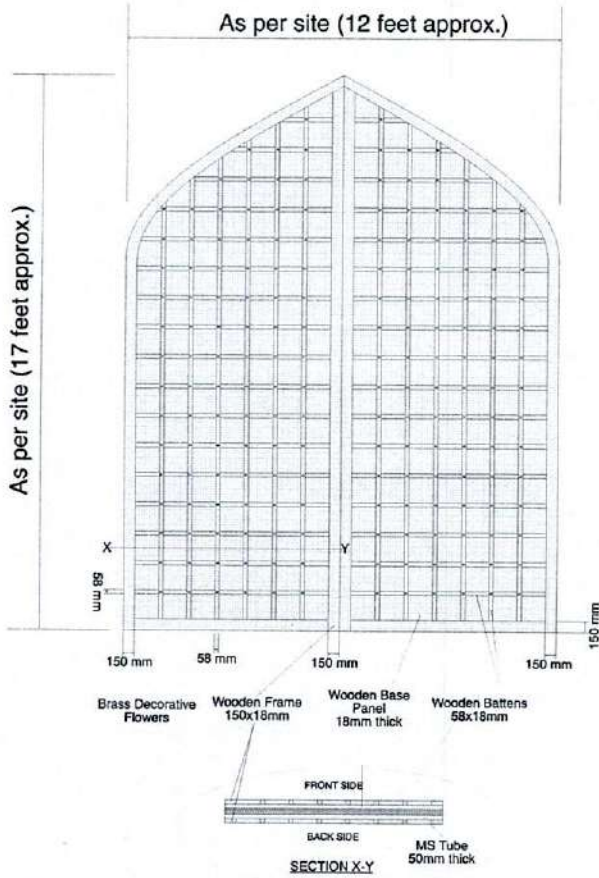

INNER M.S. FRAME DETAIL

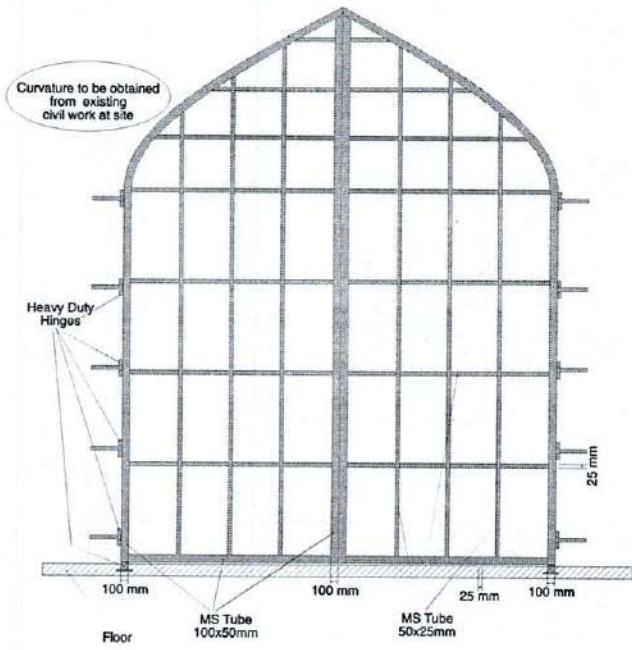

N

Drawing No. : 3
Item : Bed

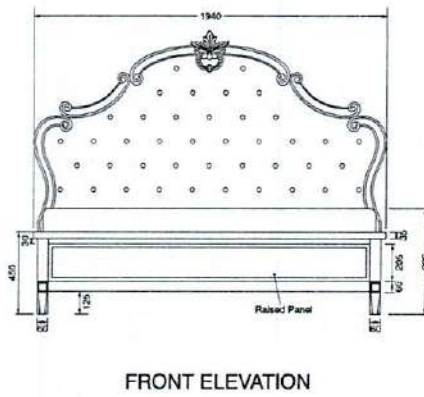
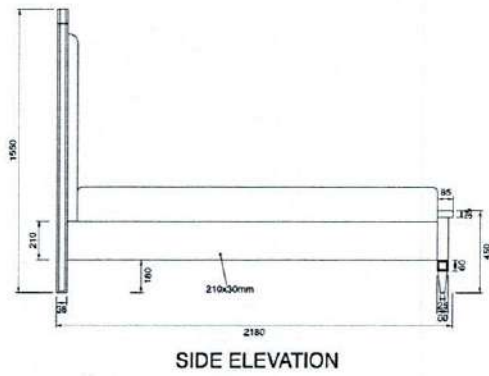
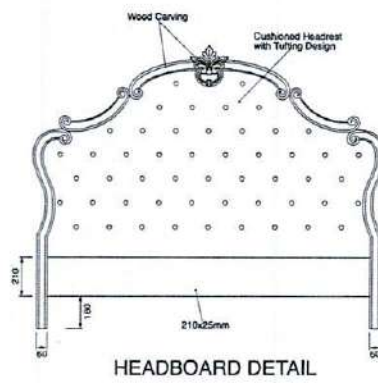
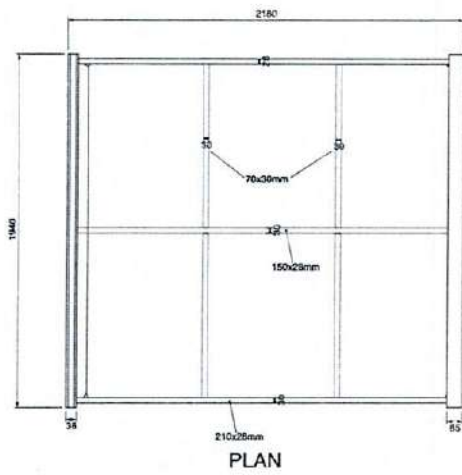

N

Drawing No. : 4
Item : Bedside Cabinet

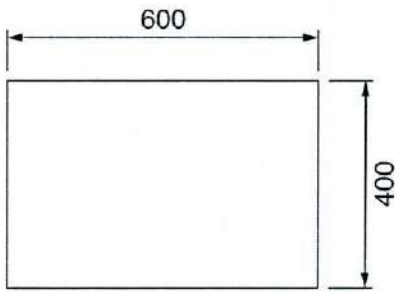

PLAN

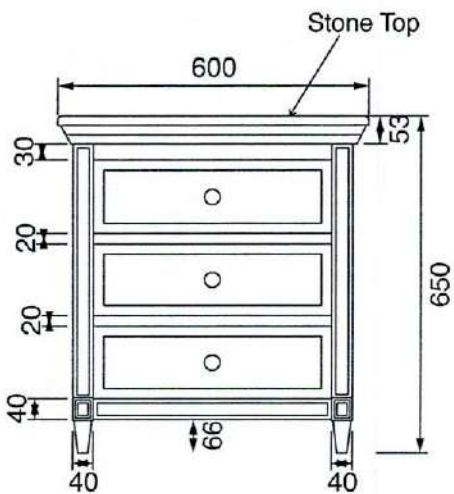

FRONT ELEVATION

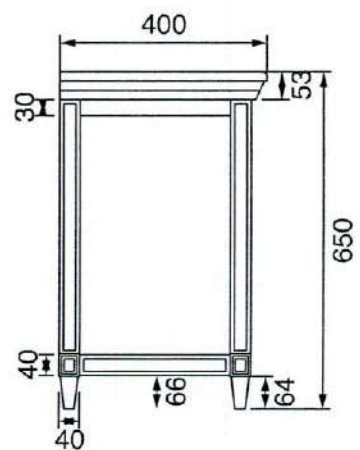

SIDE ELEVATION

W

Drawing No. : 5
Item : Desk with Fridge Cabinet

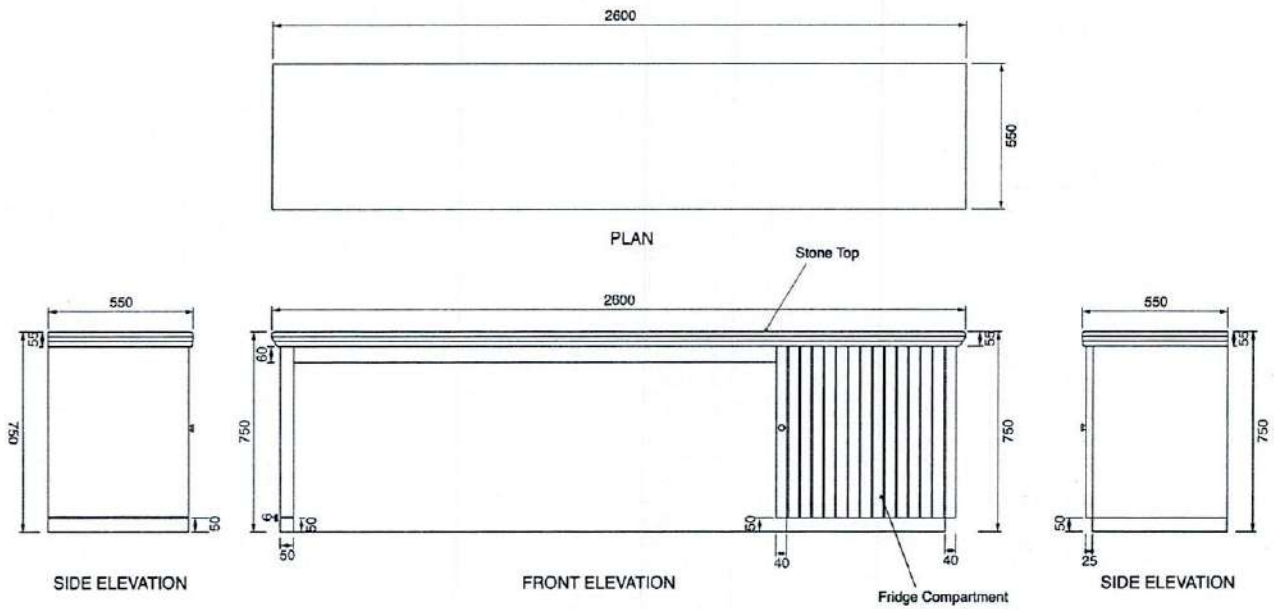

Handwritten signature

Drawing No. : 6
Item : Chair with Armrest

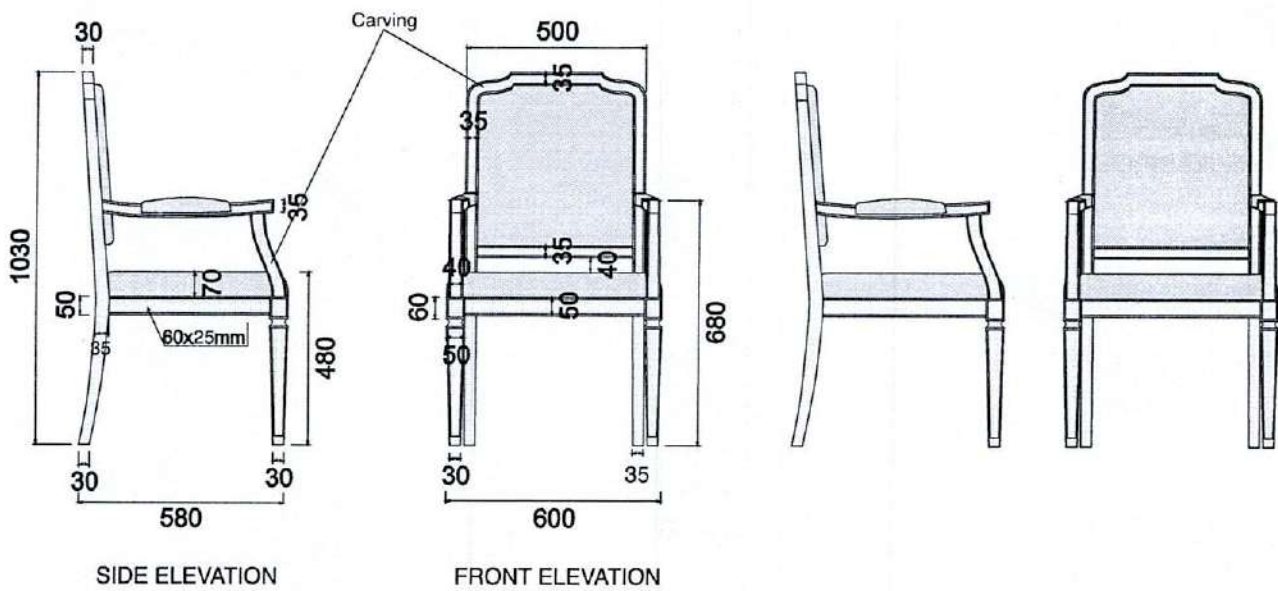

M

Drawing No. : 7
Item : Luggage Table

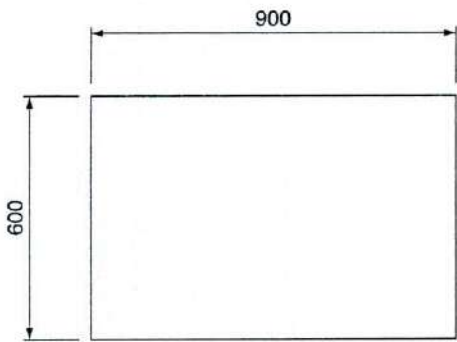

PLAN

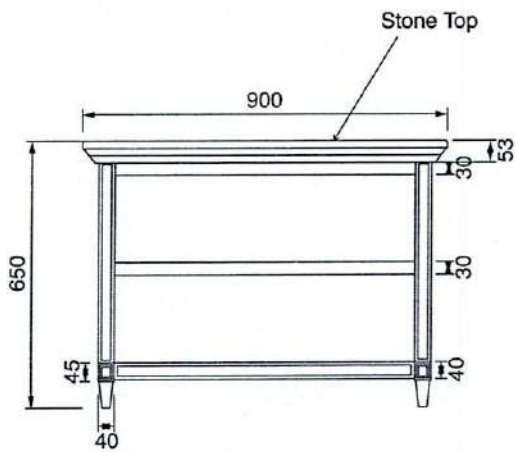

FRONT ELEVATION

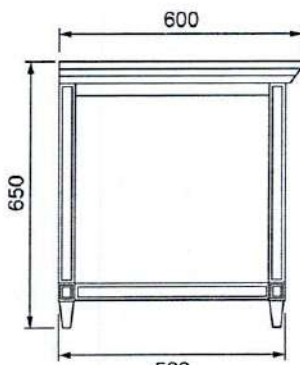

SIDE ELEVATION

N

Drawing No. : 8
Item : Wardrobe

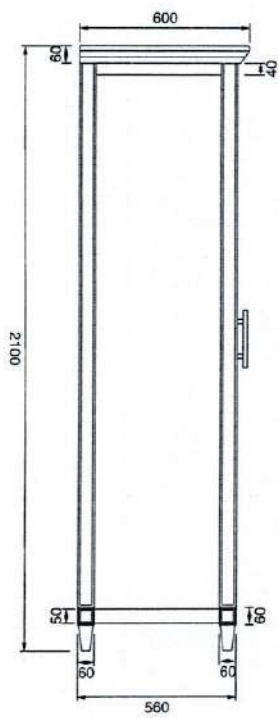

SIDE ELEVATION

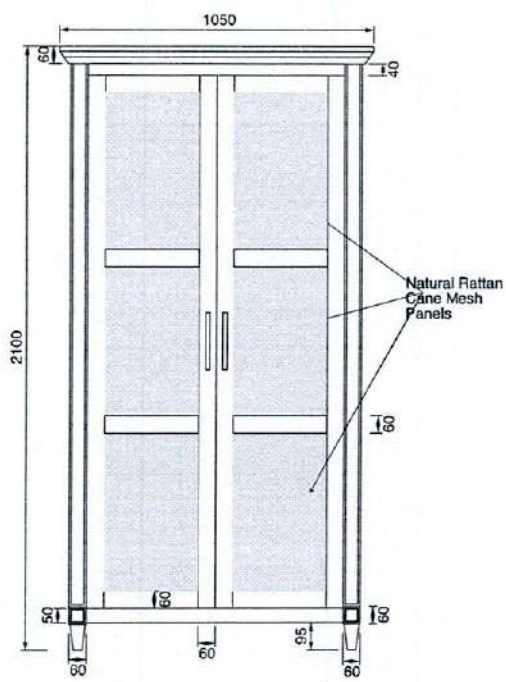

FRONT ELEVATION

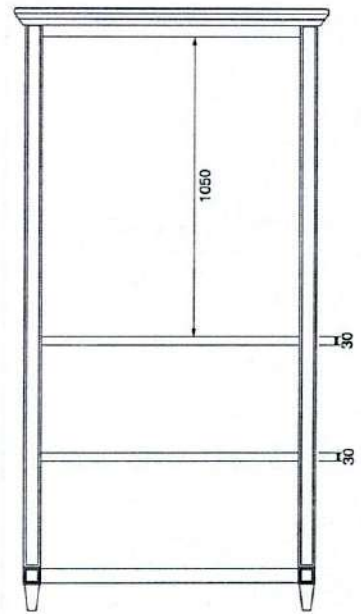

INNER DETAIL

Handwritten mark

Drawing No. : 9
Item : Sofa Chair

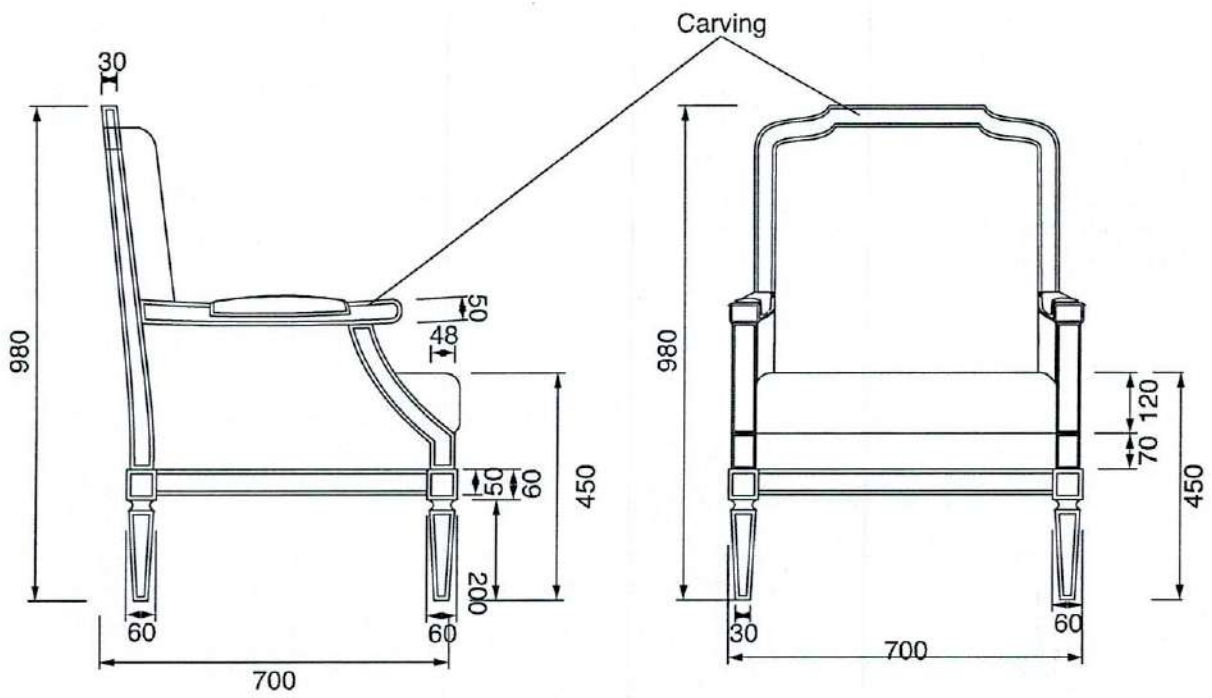

W

Drawing No. : 10
Item : Sofa 03 Seater

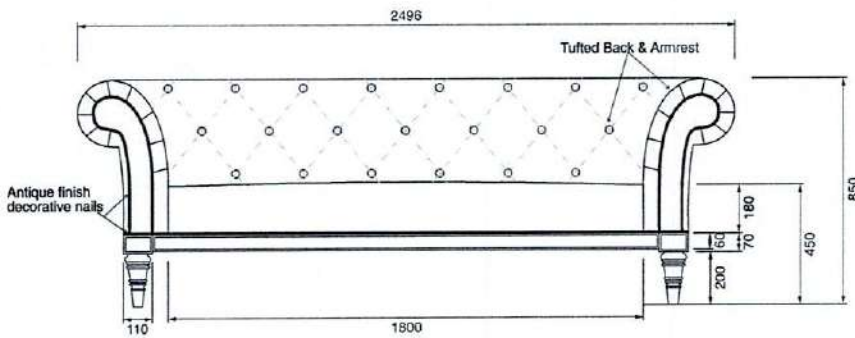

FRONT ELEVATION

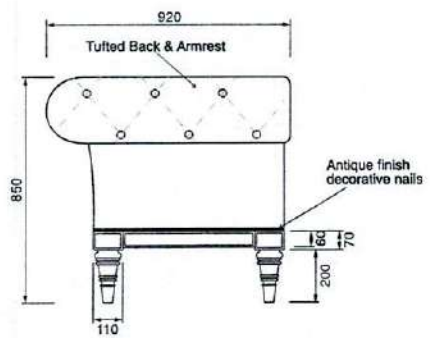

SIDE ELEVATION

N

Drawing No. :11
Item : Sofa 02 Seater

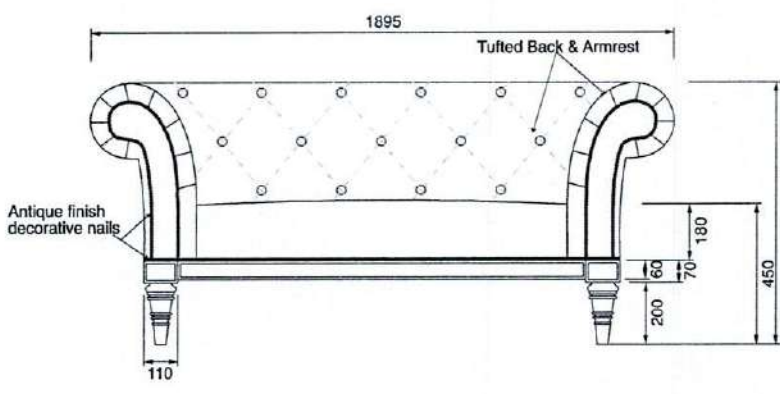

FRONT ELEVATION

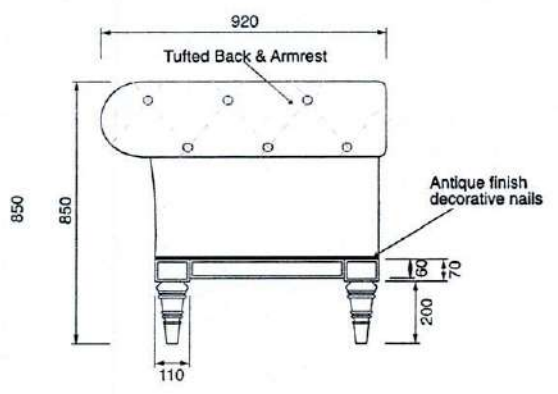

SIDE ELEVATION

~

Drawing No. : 12
Item : Centre Table

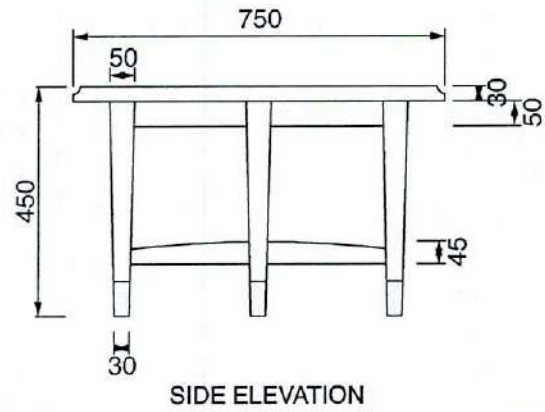
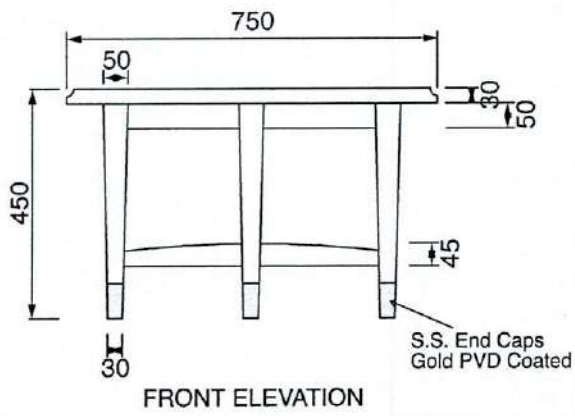
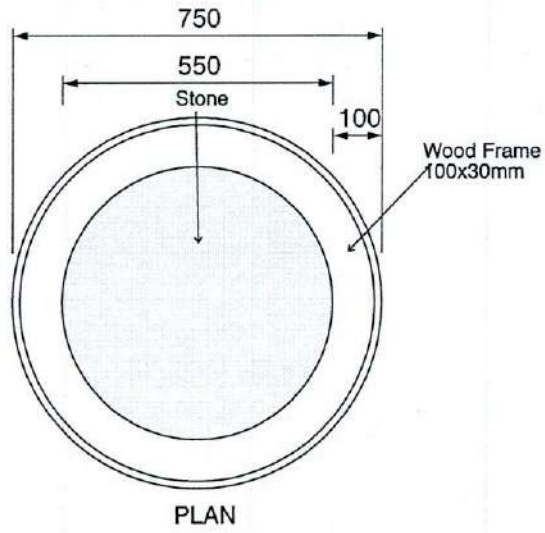

N

Drawing No. : 13
Item : Side Table

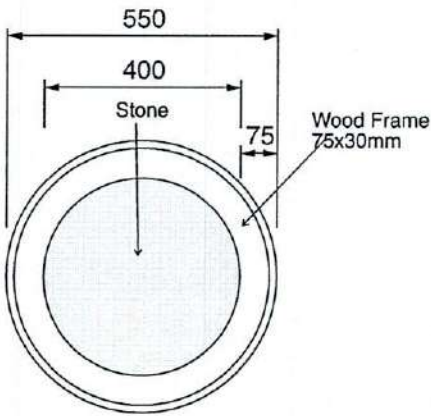

PLAN

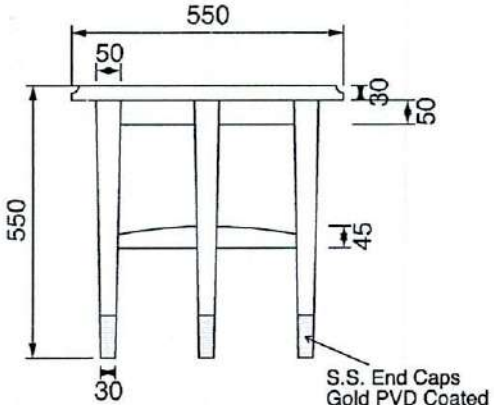

FRONT ELEVATION

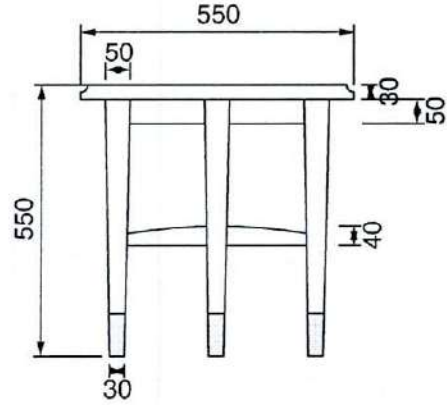

SIDE ELEVATION

W

Drawing No. : 14
Item : Dining Table

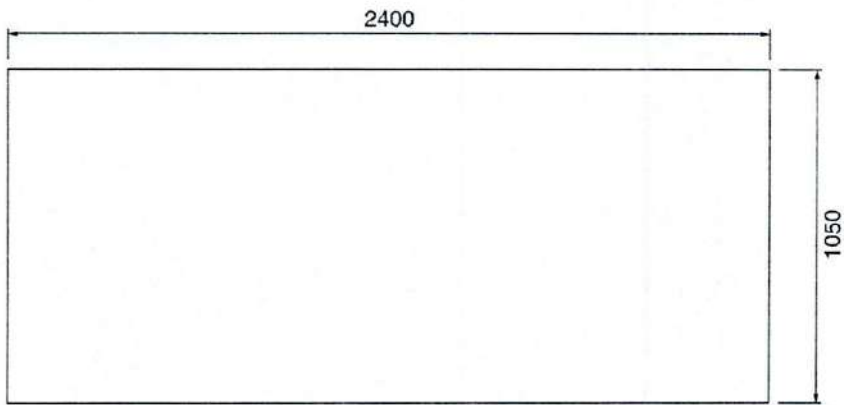

PLAN

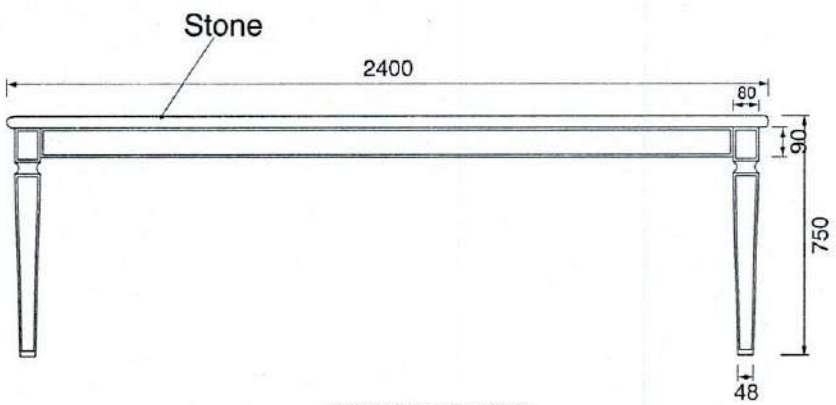

FRONT ELEVATION

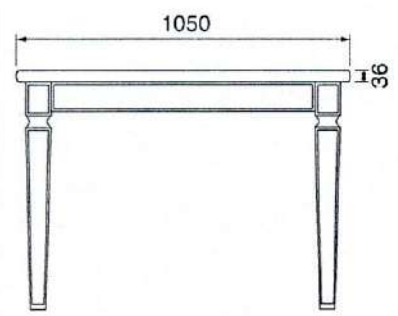

SIDE ELEVATION

Drawing No. : 15
Item : Chair

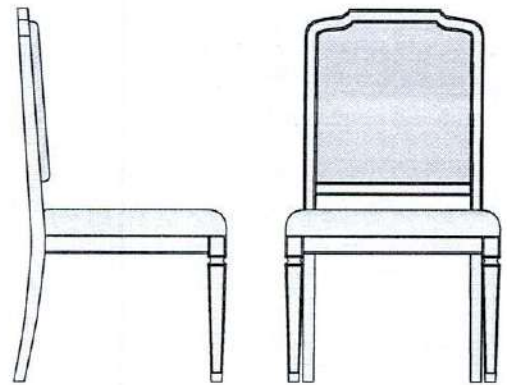
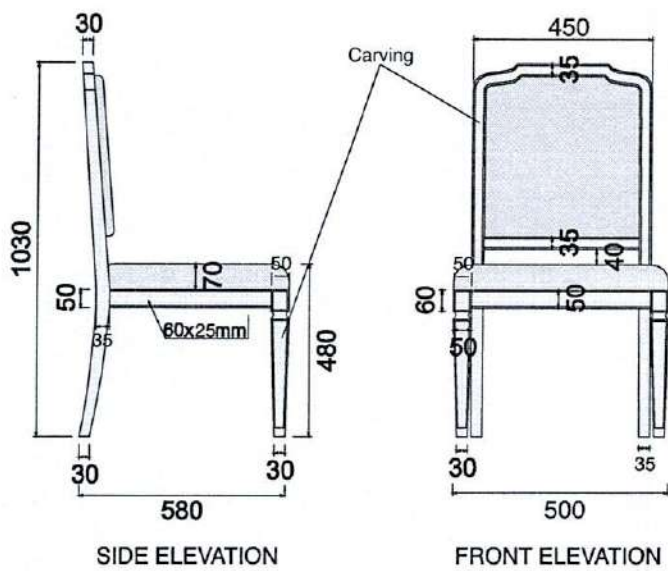

W

Drawing No. : 16
Item : Sideboard

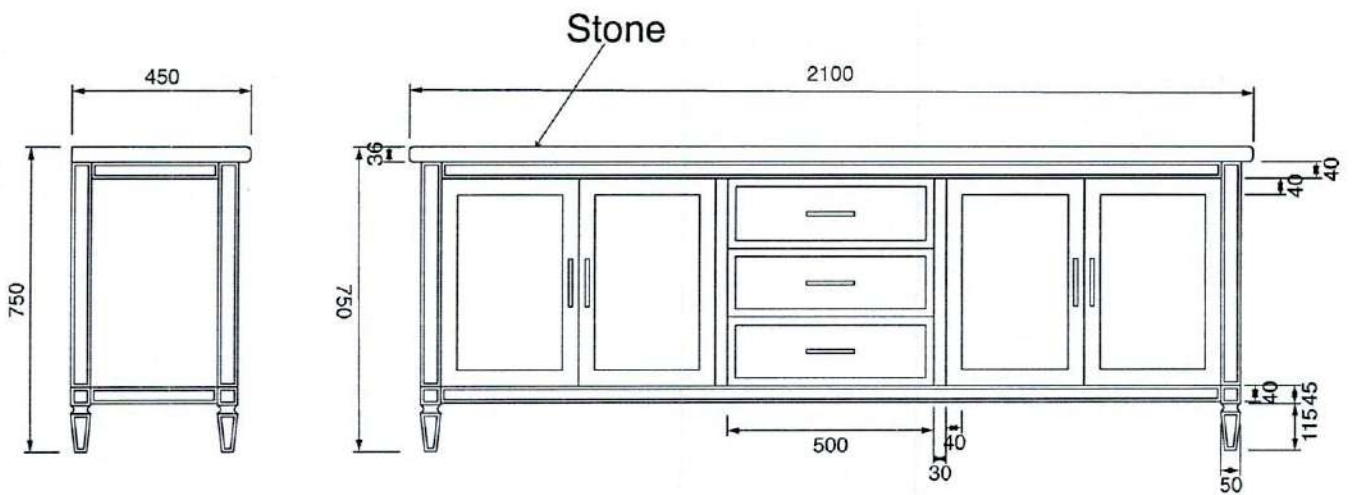

N

Drawing No. : 17
Item : Bed

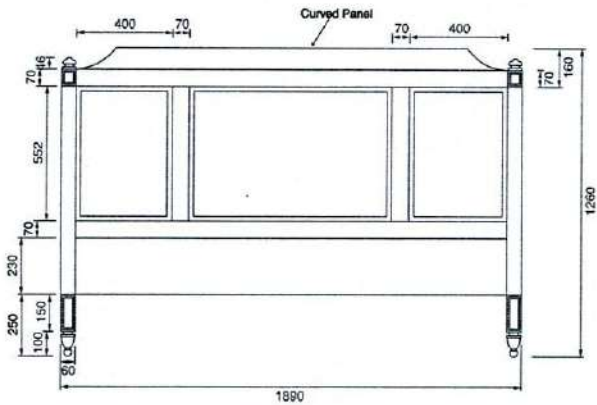

HEADBOARD DETAIL

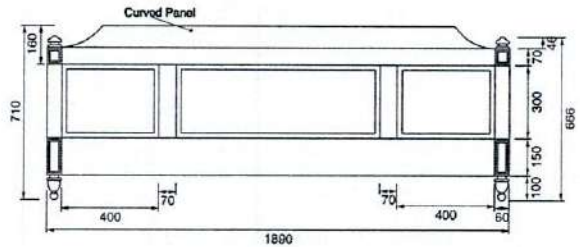

FOOTBOARD DETAIL

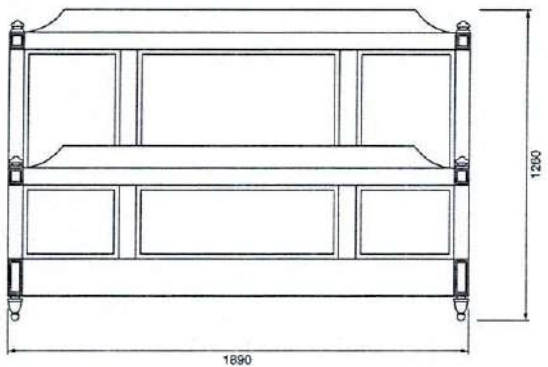

FRONT ELEVATION

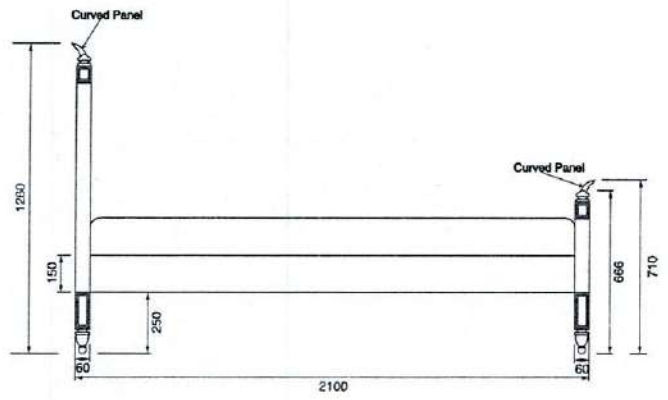

SIDE ELEVATION

Drawing No. : 18
Item : Bed

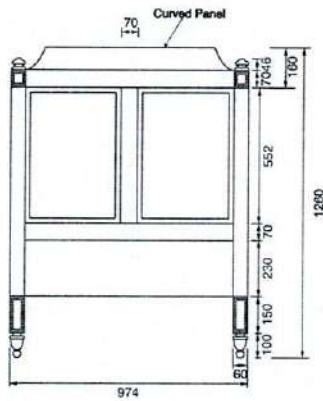

HEADBOARD DETAIL

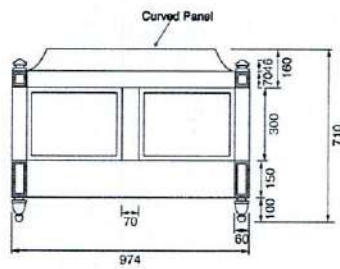

FOOTBOARD DETAIL

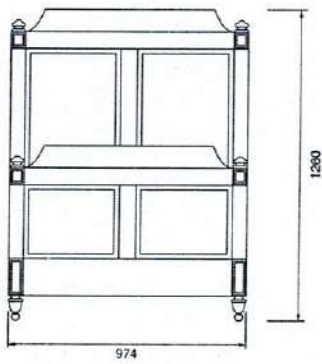

FRONT ELEVATION

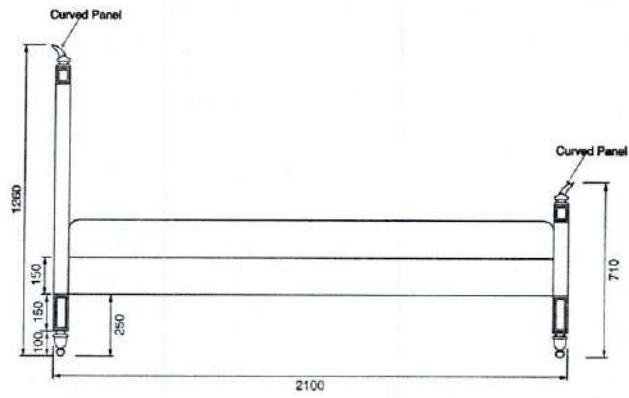

SIDE ELEVATION

Drawing No. : 19
Item : Bedside Cabinet

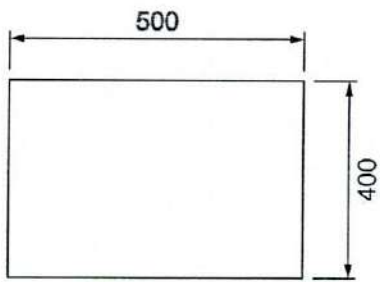

PLAN

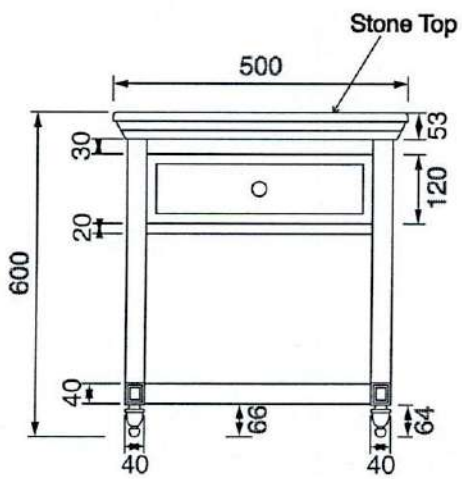

FRONT ELEVATION

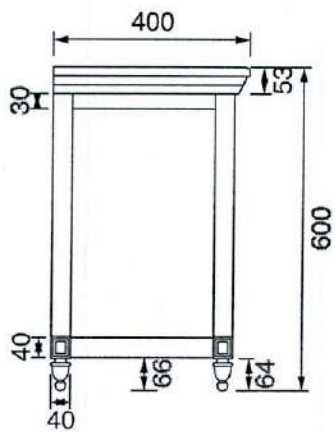

SIDE ELEVATION

Drawing No. : 20
 Item : Writing Desk

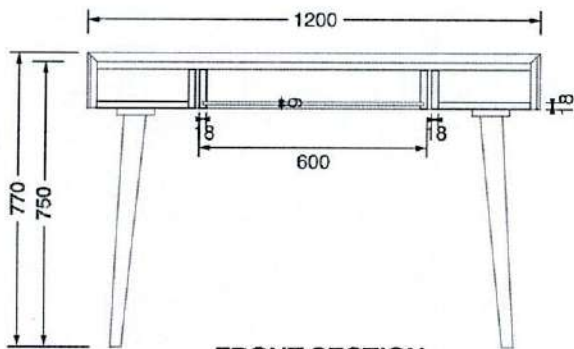

FRONT SECTION

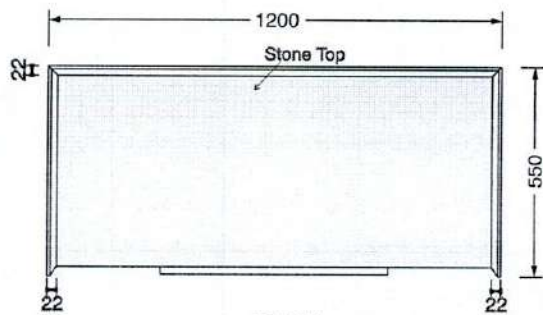

PLAN

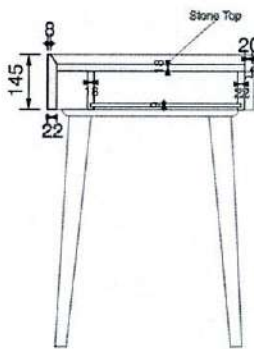

SIDE SECTION

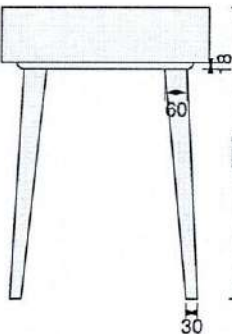

SIDE ELEVATION

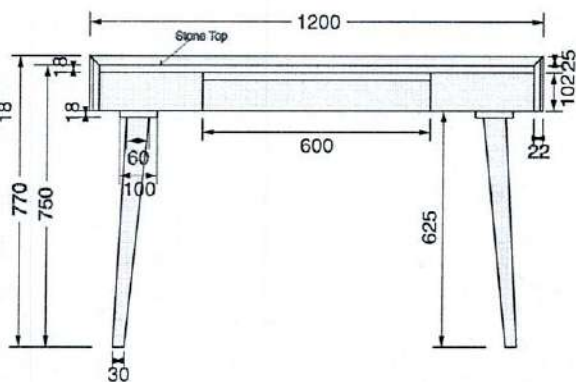

FRONT ELEVATION

Drawing No. : 21
Item : Chair

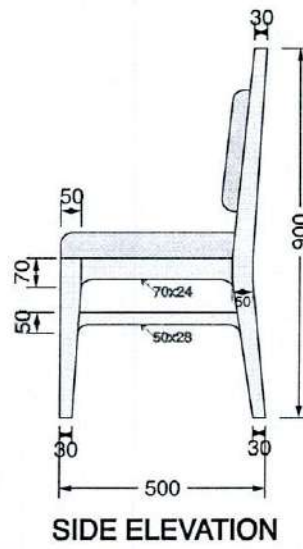
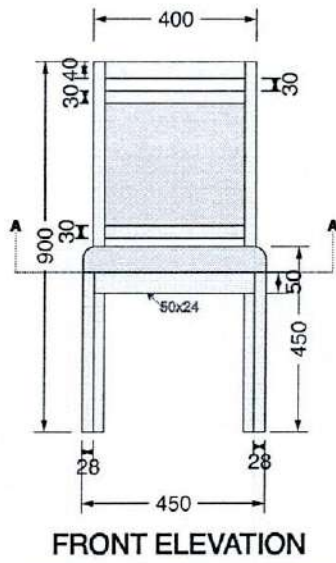
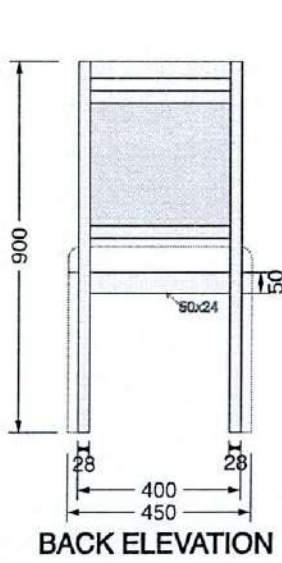
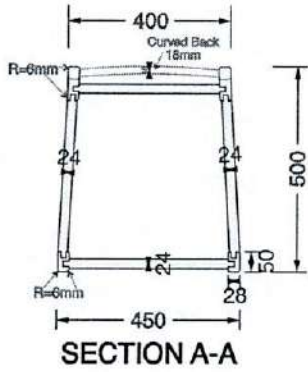

Drawing No. : 22
Item : Table with Fridge Cabinet

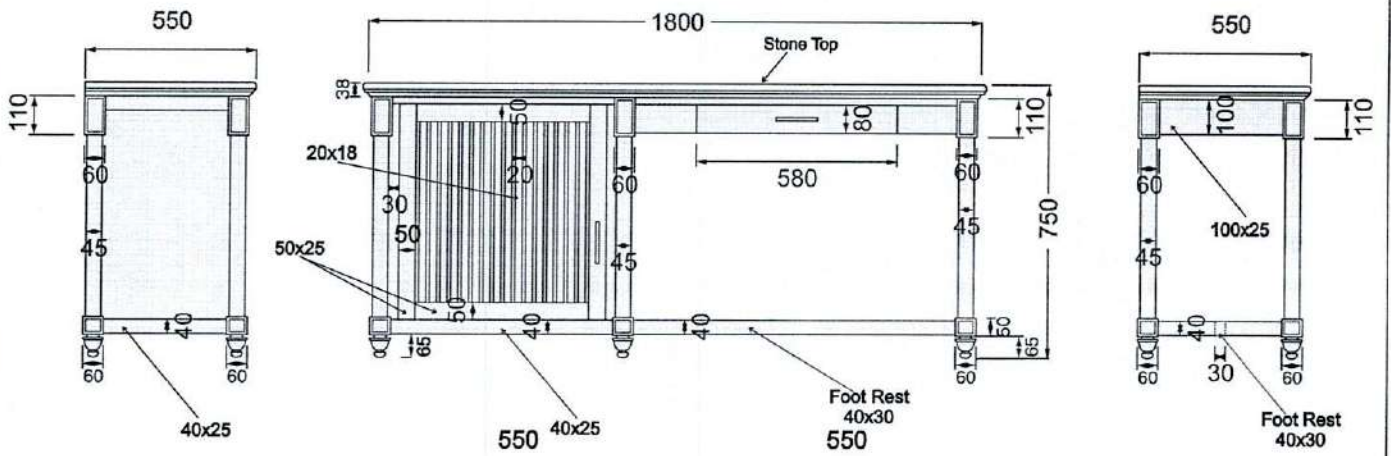

RIGHT SIDE ELEVATION

FRONT ELEVATION

LEFT SIDE ELEVATION

Drawing No. : 23
Item : Sofa Chair

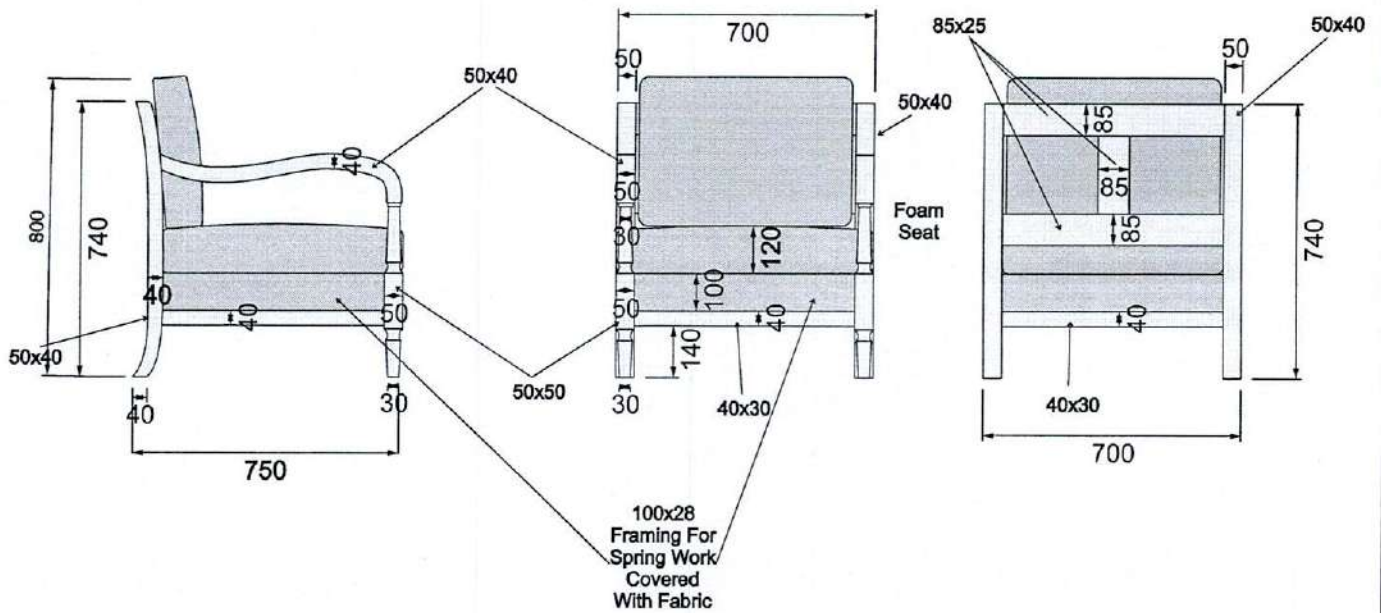

SIDE ELEVATION

FRONT ELEVATION

BACK ELEVATION

M

Drawing No. : 24
Item : Side Table

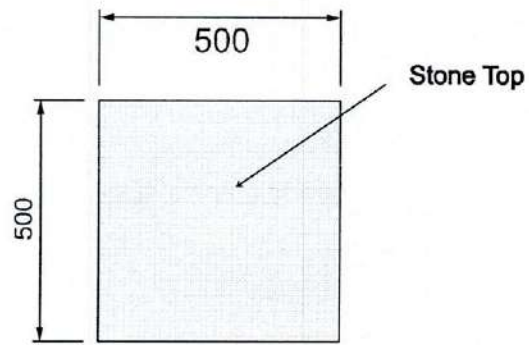

TOP VIEW

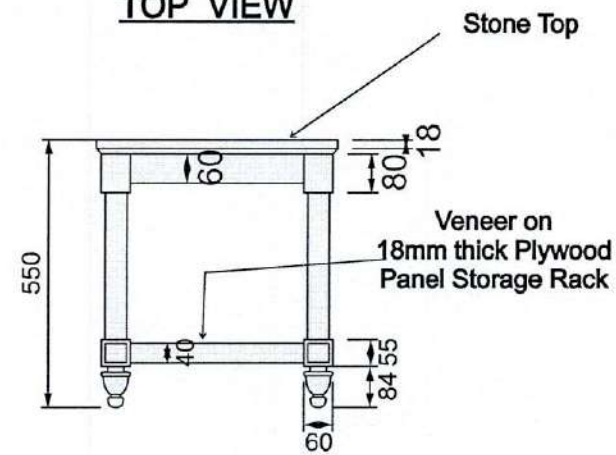

FRONT / SIDE ELEVATION

Drawing No. : 25
Item : Luggage Table

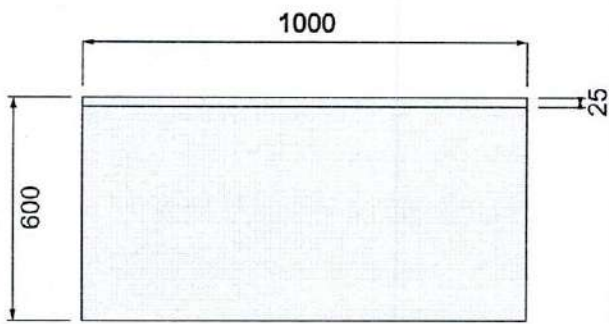

PLAN

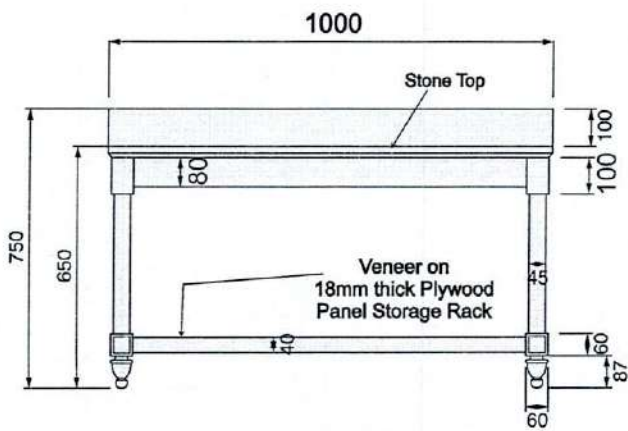

FRONT ELEVATION

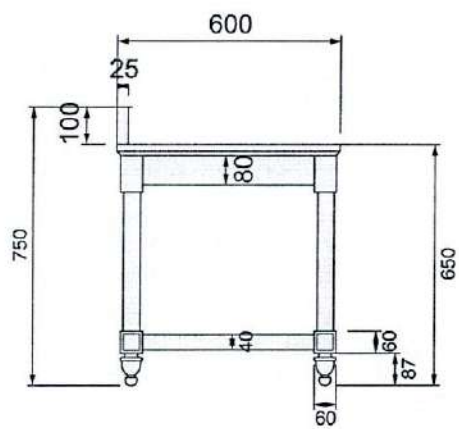

SIDE ELEVATION

Drawing No. : 26
Item : Wardrobe

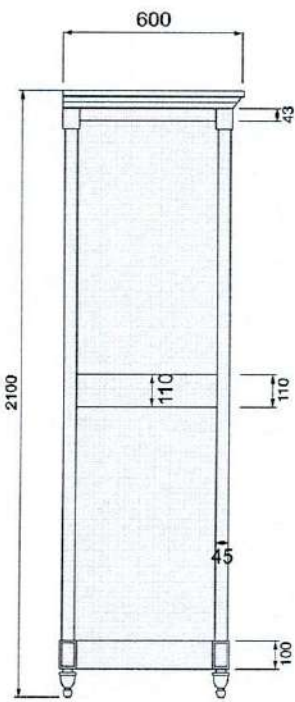

SIDE ELEVATION

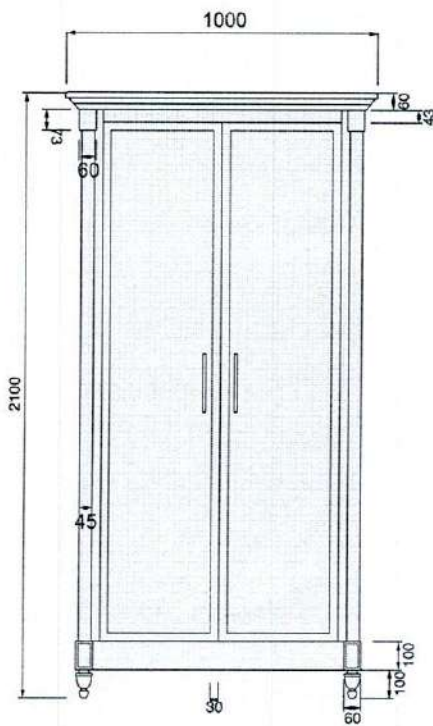

FRONT ELEVATION

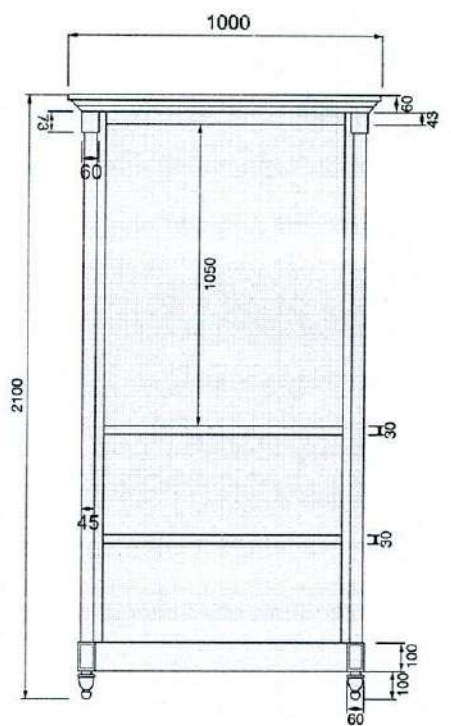

INNER DETAIL



Drawing No. : 27
Item : Bunk Bed

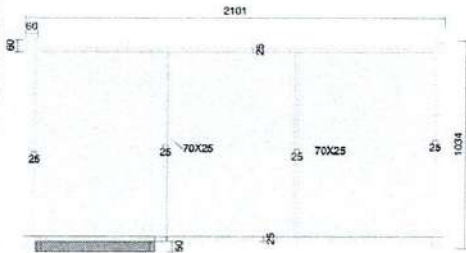

PLAN

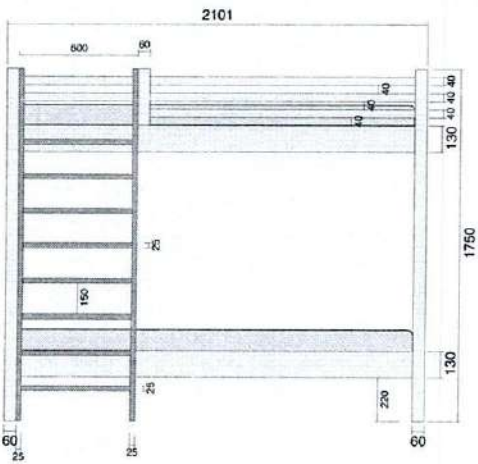

FRONT ELEVATION

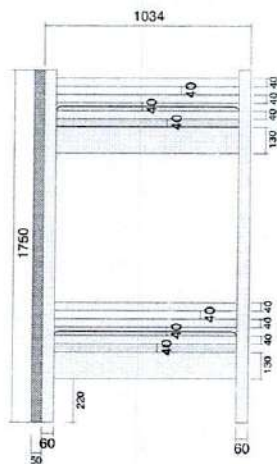

SIDE ELEVATION

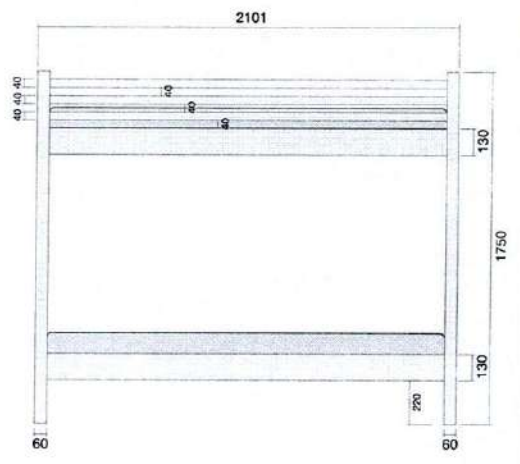

BACK ELEVATION

Drawing No. : 28
Item : Bedside Cabinet

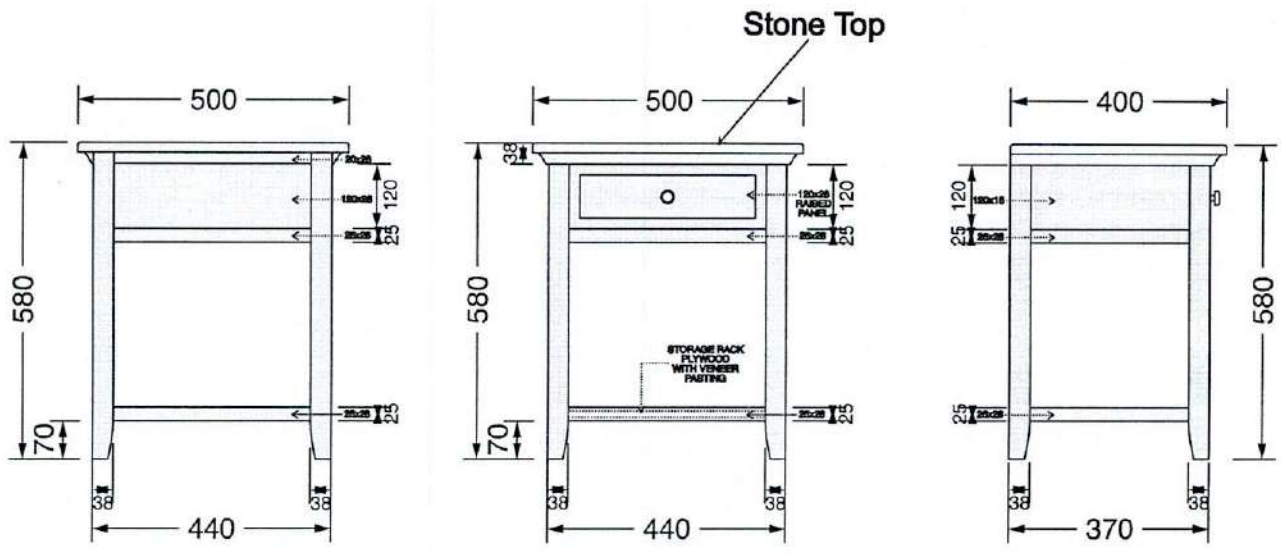

BACK ELEVATION

FRONT ELEVATION

SIDE ELEVATION

Drawing No. : 29
Item : Sofa 02 Seater

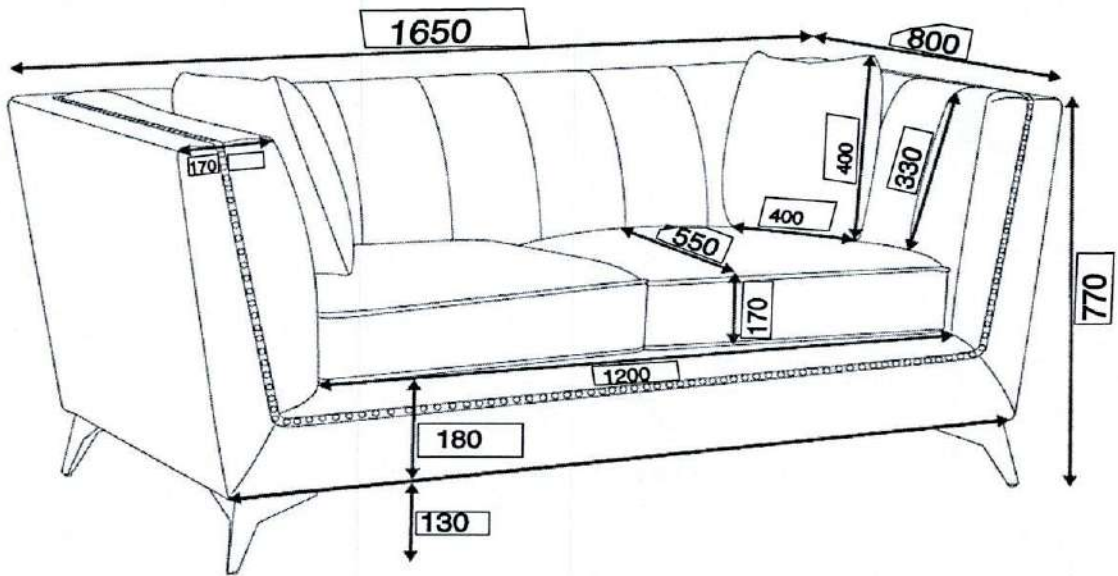

W

Drawing No. : 30
Item : Sofa 03 Seater

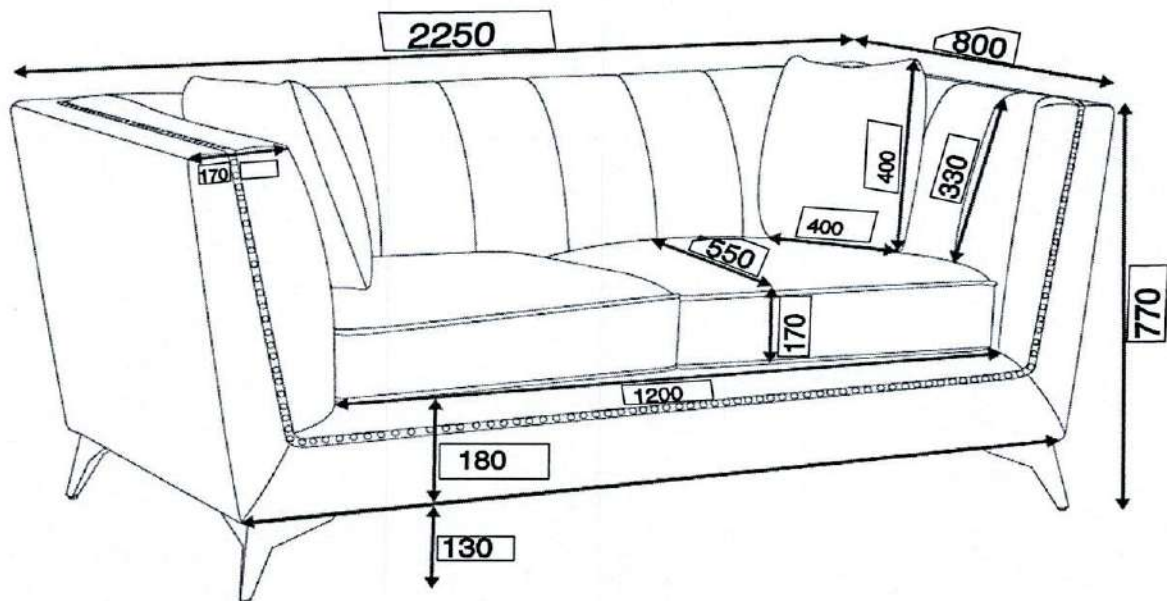

Drawing No. : 31
Item : Centre Table

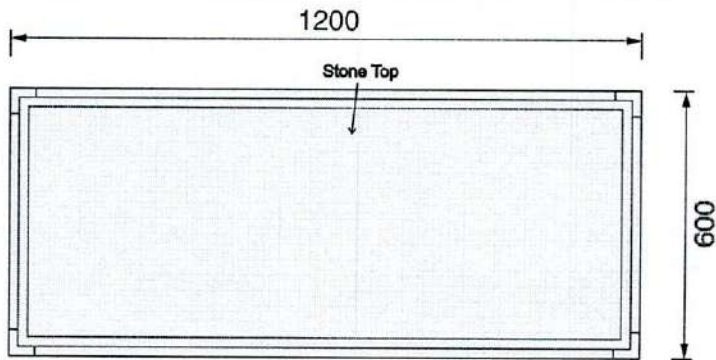

PLAN

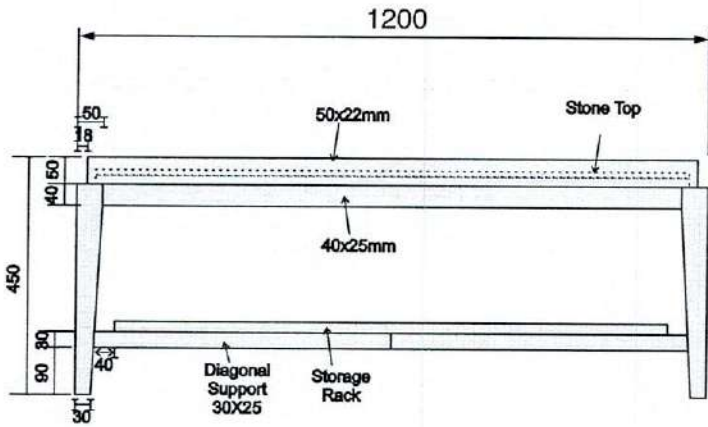

FRONT ELEVATION

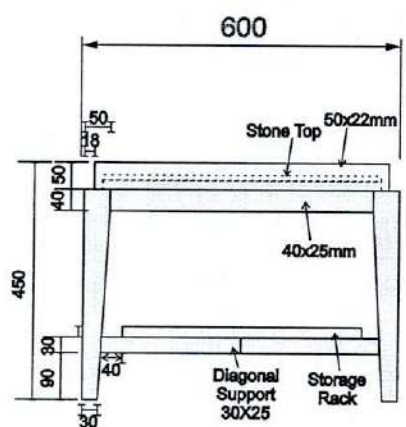

SIDE ELEVATION

Drawing No. : 32
Item : Side Table

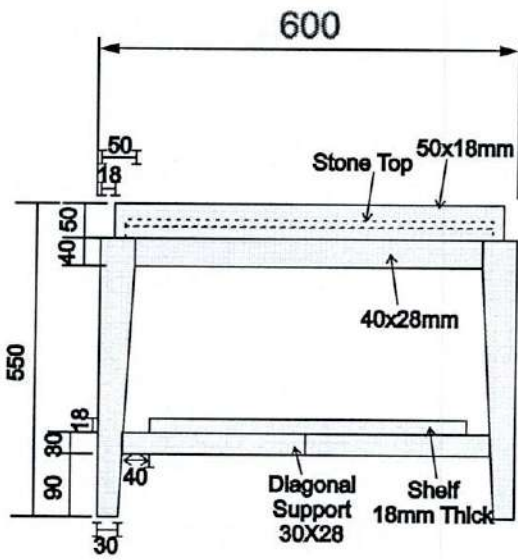

FRONT ELEVATION

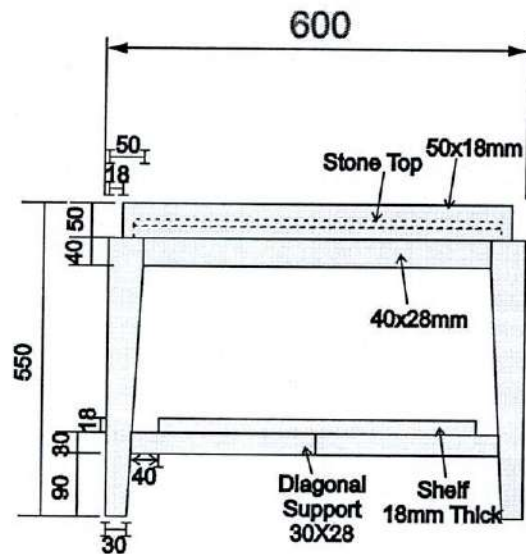

SIDE ELEVATION

Drawing No. : 33
Item : Dining Table

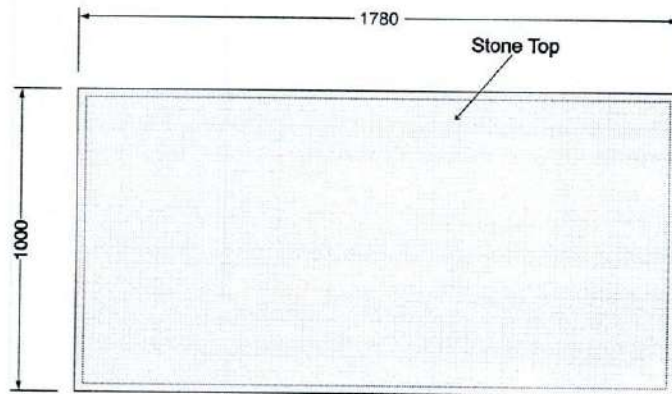

PLAN

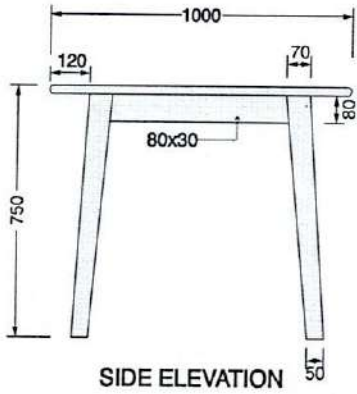

SIDE ELEVATION

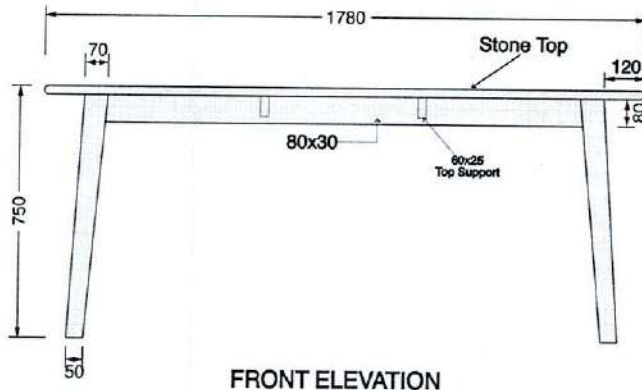

FRONT ELEVATION

Drawing No. : 34

Item : Dining Table

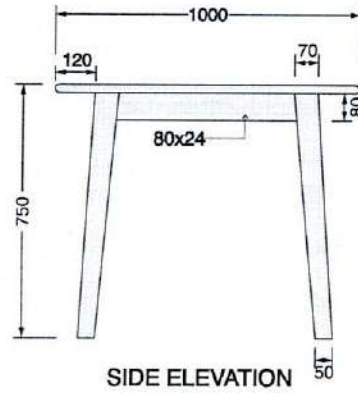
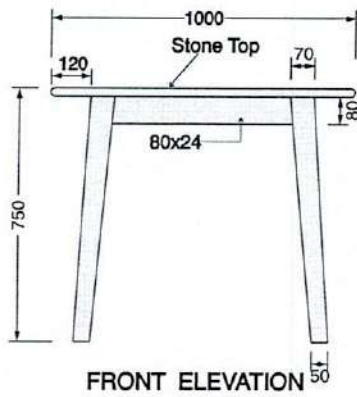
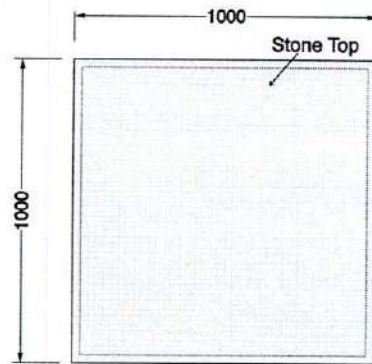

Drawing No. : 35
Item : Chair

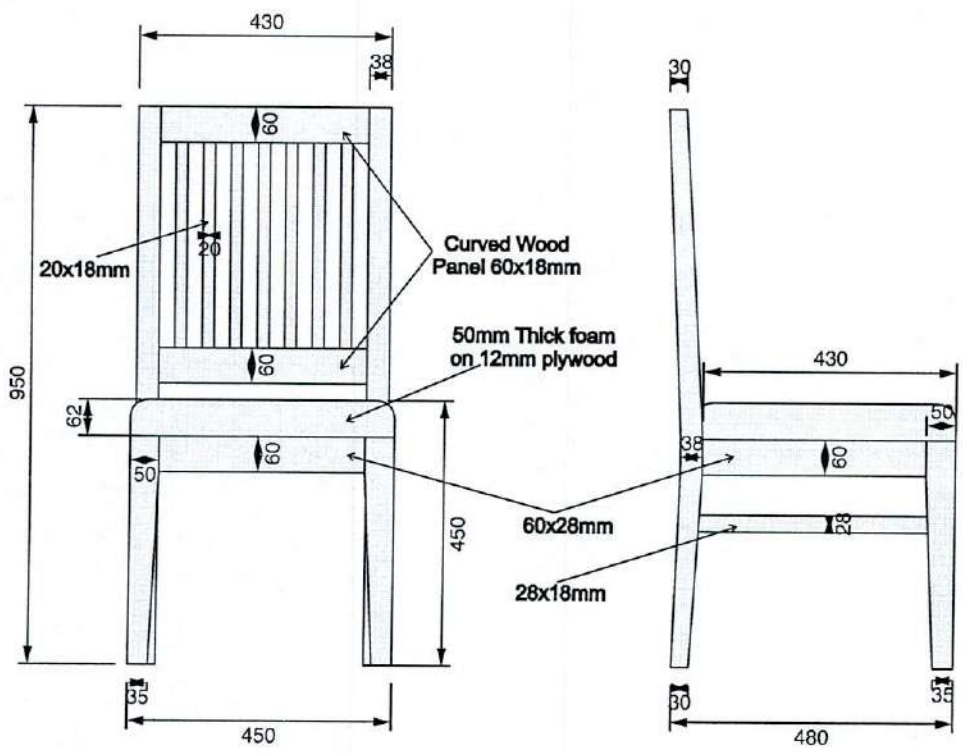

Drawing No. : 36
Item : Sideboard

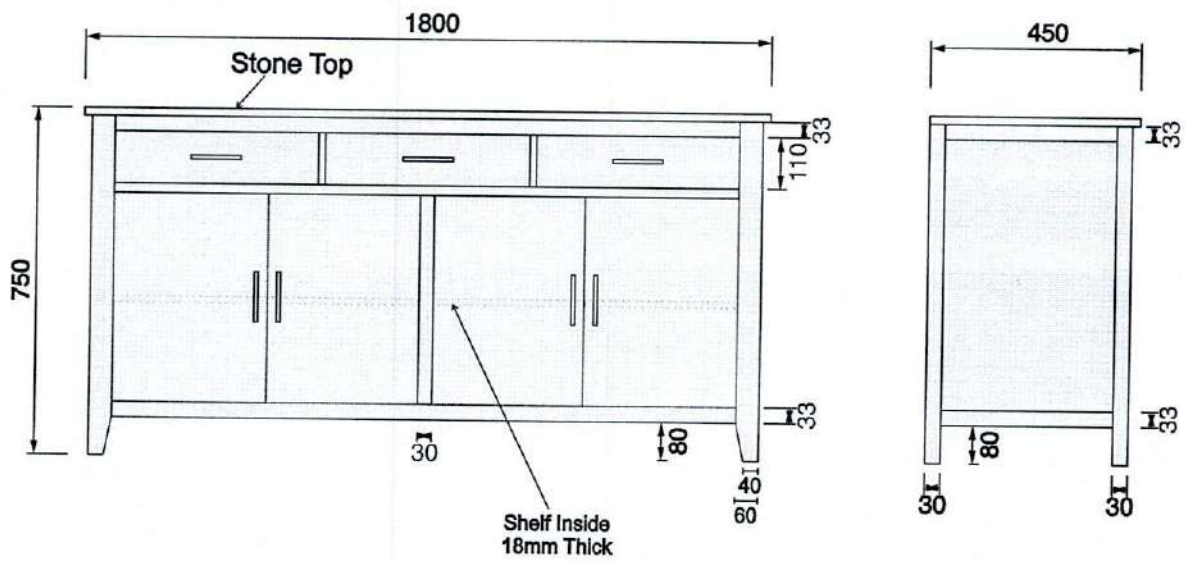

Drawing No. : 37
Item : Mirror with Frame

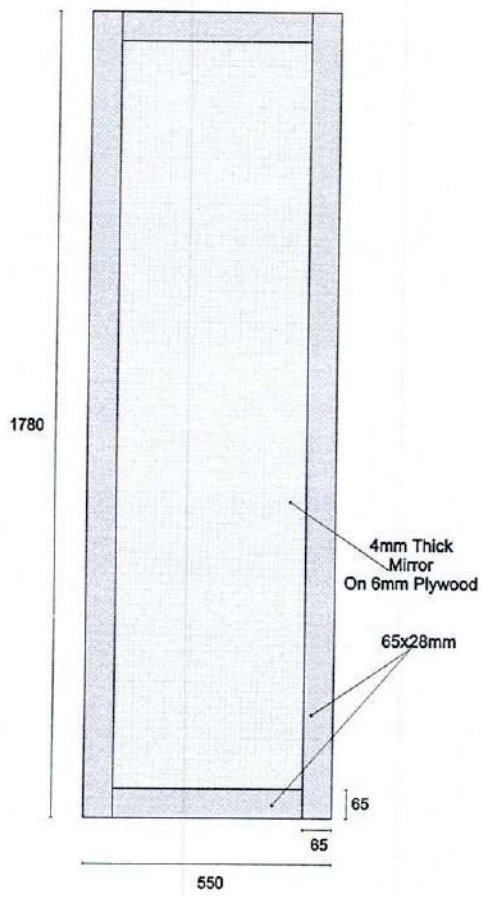

Drawing No. : 38
Item : Wall Panelling

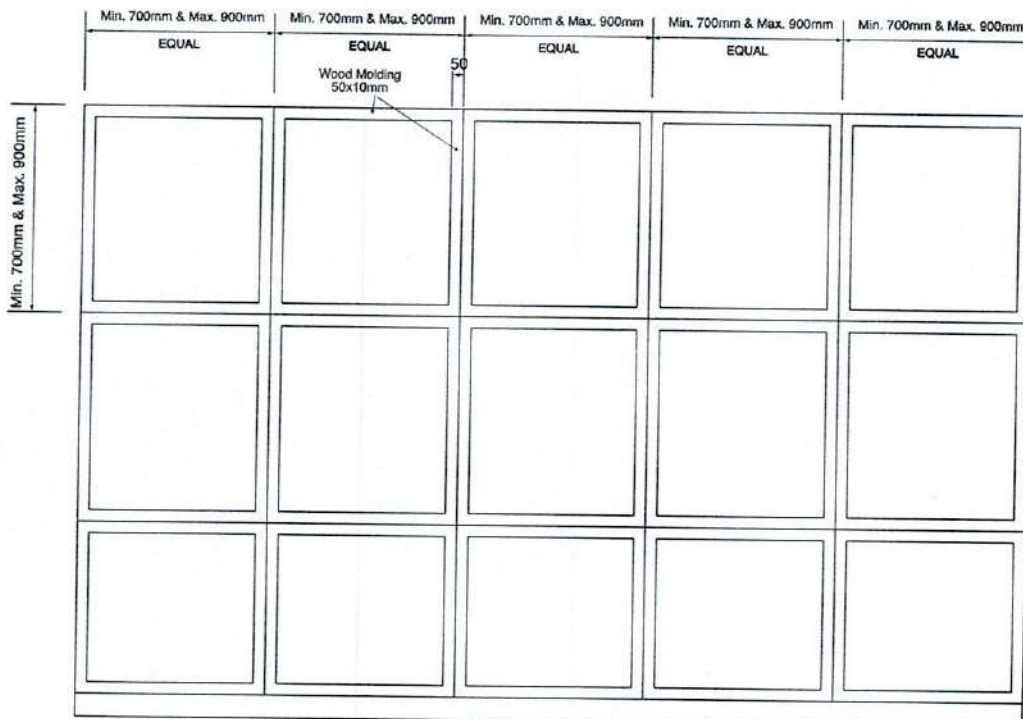

N

Drawing No. : 39
Item : Office Desk with Side Unit

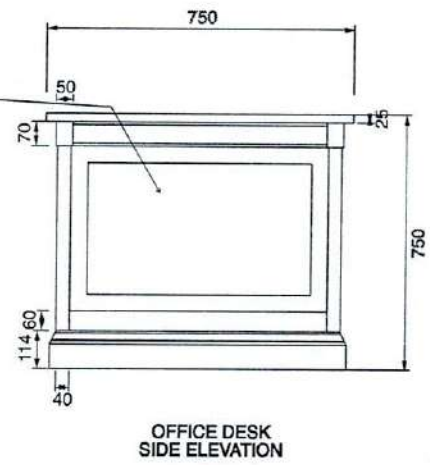
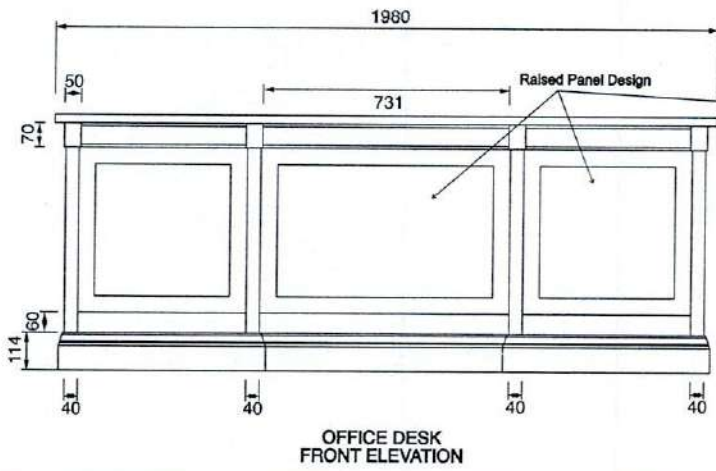
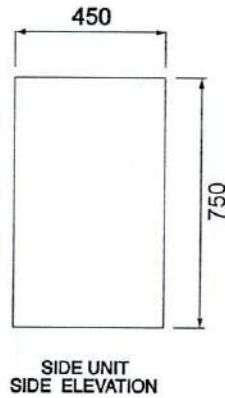
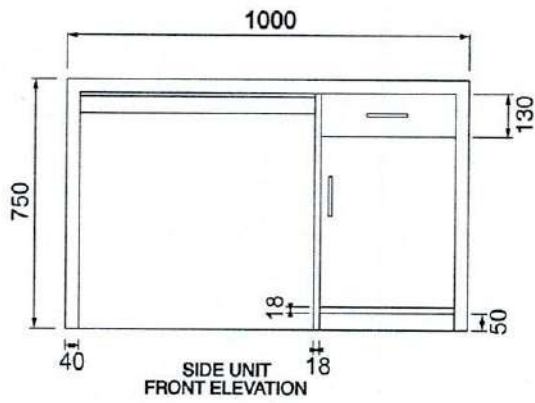

Drawing No. : 40
Item : Office Desk with Side Unit

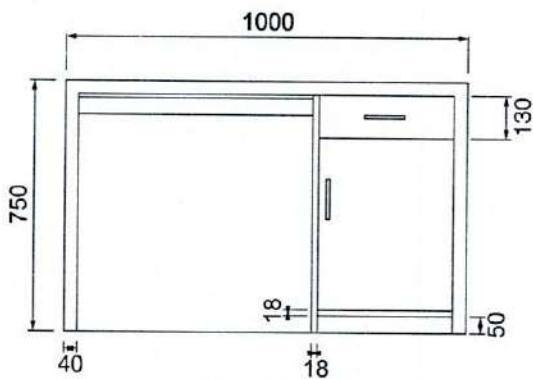

SIDE UNIT
FRONT ELEVATION

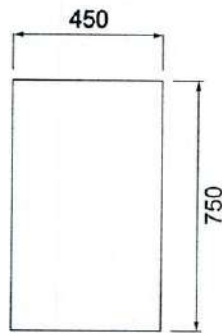

SIDE UNIT
SIDE ELEVATION

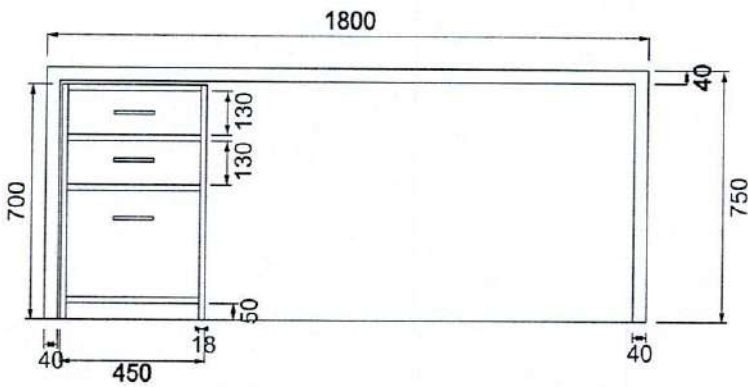

OFFICE DESK
FRONT ELEVATION

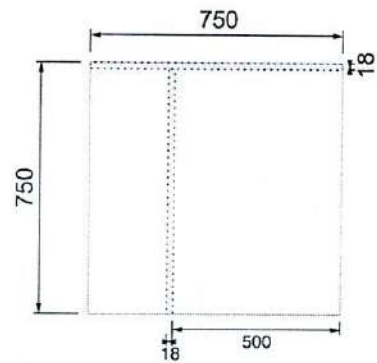

OFFICE DESK
SIDE ELEVATION

N

Drawing No. : 41
Item : Sofa 03 Seater

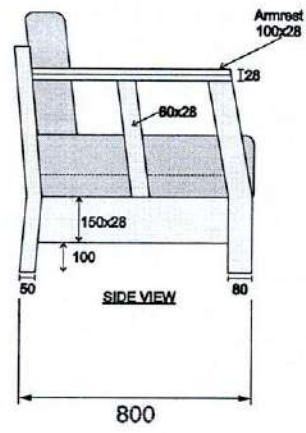
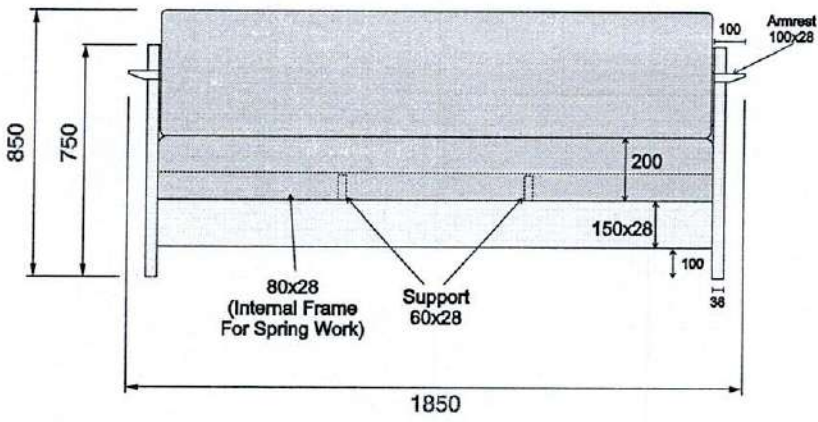
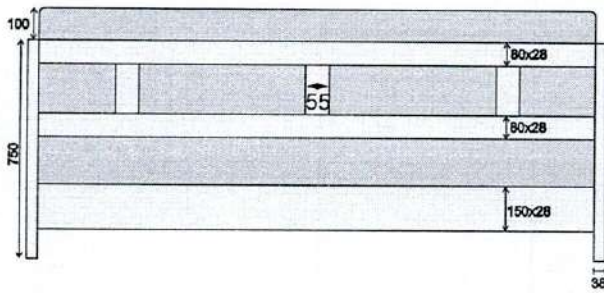

N